

**SERVICE MANUAL
&
PARTS LIST**

MODEL: E1030

Contents

WHAT TO DO WHEN	1 - 3
CHANGING EXTERNAL PARTS	
FACE COVER	4
FREE ARM COVER	5
FRONT COVER	6
REAR COVER.....	7
MECHANICAL ADJUSTMENT	
PRESSER BAR HEIGHT	8
NEEDLE DROP POSITION.....	9
ADJUSTMENT OF HOOK TIMING	10
ADJUSTMENT OF NEEDLE BAR HEIGHT	11
CLEARANCE BETWEEN NEEDLE AND TIP OF THE ROTARY HOOK	12
FEED DOG HEIGHT	13
BACKLASH BETWEEN HOOK GEAR AND LOWER SHAFT GEAR	14
TOP TENSION	15
STRETCH STITCH FEED BALANCE	16
REPLACEMENT AND ADJUSTMENT OF THE NEEDLE THREAD PLATE	17
SELF-DIAGNOSTIC TEST	
SELF-DIAGNOSTIC TEST	18-22
TO DISPLAY THE VERSION OF THE PROGRAM.....	22
REPLACING THE ELECTRONIC COMPONENTS	
PRINTED CIRCUIT BOARD A CONNECTION	23
PRINTED CIRCUIT BOARD A	24
PRINTED CIRCUIT BOARD L.....	25
DRIVING MOTOR (DC MOTOR)	36
SWITCHING REGULATOR UNIT.....	27
PARTS LIST	28-41

WHAT TO DO WHEN

Condition	Cause	How to fix	Reference
<p>1. Skipping Stitches</p>	<ol style="list-style-type: none"> 1. Needle is not inserted properly. 2. Needle is bent or worn. 3. Incorrectly threaded. 4. Needle or thread are inappropriate for the fabric being sewn. 5. Sewing on stretch fabric. 6. Inappropriate needle bar height. 7. Inappropriate needle to hook timing. 8. Inappropriate needle to hook clearance. 	<p>Insert the needle properly.</p> <p>Change the needle.</p> <p>Rethread.</p> <p>Use the recommended sewing needle and the thread.</p> <p>Use a HAx1 #11 blue tip needle.</p> <p>See mechanical adjustment “Adjustment of Needle bar height”.</p> <p>See mechanical adjustment “Adjustment of Hook timing”.</p> <p>See mechanical adjustment “Clearance between needle and tip of the rotary hook”.</p>	<p>P. 11</p> <p>P. 10</p> <p>P. 12</p>
<p>2. Fabric is not moving</p>	<ol style="list-style-type: none"> 1. Incorrect feed dog height. 2. Feed dog is in the down position. 3. Thread on the bottom side of the fabric is jammed up. 4. Feed dog teeth are worn. 	<p>Adjust the presser bar level to make the pressure stronger. See mechanical adjustment “Feed dog height”.</p> <p>Raise the feed dog.</p> <p>Make sure to bring both needle and bobbin threads under the foot when start sewing.</p> <p>Change the feed dog.</p>	<p>P. 13</p>

Condition	Cause	How to Fix	Reference
3. Breaking upper thread.	<ol style="list-style-type: none"> 1. Initial sewing speed is too fast. 2. Thread path is incorrect. 3. Needle is bent or dull. 4. Top tension is too strong. 5. Needle size is inappropriate for fabric. 6. Needle eye is worn. 7. Needle hole in needle plate is worn or burred. 	<p>Start with medium speed.</p> <p>Use the proper thread path.</p> <p>Replace with a new needle.</p> <p>Adjust top tension correctly.</p> <p>Use appropriate needle for fabric and thread in use.</p> <p>Change the needle.</p> <p>Repair the hole or replace the needle plate.</p>	
4. Breaking bobbin thread.	<ol style="list-style-type: none"> 1. Bobbin holder is incorrectly threaded. 2. Too much thread is wound on the bobbin. 3. Lint is stuck inside the bobbin holder. 4. Thread quality is too low. 5. Thread is jamming around the bobbin holder. 	<p>Set the bobbin thread correctly.</p> <p>Adjust the position of bobbin winder stopper.</p> <p>Clean the bobbin holder.</p> <p>Change to a high quality sewing thread.</p> <p>Clear out the jamming thread.</p>	
5. Needle breaks	<ol style="list-style-type: none"> 1. Needle is hitting the needle plate. 2. Needle is bent or worn. 3. Needle is hitting the hook. 4. Fabric is being pulled too strongly while sewing. 	<p>See mechanical adjustment "Needle drop position".</p> <p>Change the needle.</p> <p>See mechanical adjustment "Clearance between needle and tip of the rotary hook".</p> <p>Guide the fabric gently while sewing.</p>	<p>P. 9</p> <p>P. 12</p>

Condition	Cause	How to fix	Reference
6. Noisy operation	<ol style="list-style-type: none"> 1. Backlash between hook gear and lower shaft gear is too great. 2. Lower shaft gear is loose. 3. Inappropriate belt tension. 4. Not enough oil. 5. Upper shaft gear is loose. 	<p>Eliminate the backlash.</p> <p>Eliminate the looseness.</p> <p>See part removal and replacement “driving motor (DC motor)”.</p> <p>Oil all moving parts.</p> <p>Eliminate the looseness.</p>	P. 26
7. Deformation pattern	<ol style="list-style-type: none"> 1. Inappropriate feed balance. 2. Top tension is too strong. 	<p>Adjust the feed balancing screw.</p> <p>See mechanical adjustment “Top tension”.</p>	<p>P. 16</p> <p>P. 15</p>

CHANGING EXTERNAL PARTS

FACE COVER

To remove:

1. Remove the setscrew ①.
2. Remove the face cover ②.

To attach:

3. Follow the above procedure in reverse.



CHANGING EXTERNAL PARTS

Bed cover

To remove:

1. Remove the setscrew ①.
2. Remove the setscrew ②.
3. Move the bed cover ③ to the left to unlock the cover.
4. Slide the bed cover to the up to remove the cover.

To attach:

5. Follow the above procedures in reverse.

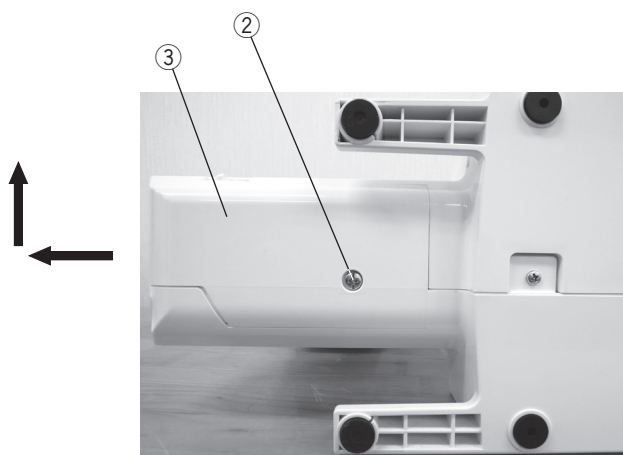
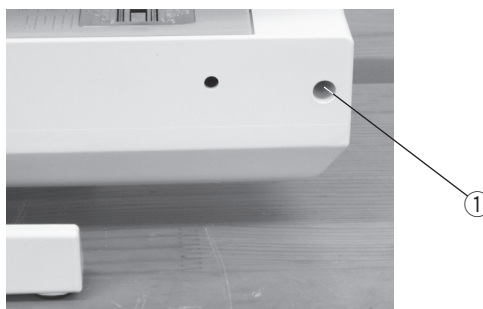

CHANGING EXTERNAL PARTS

FRONT COVER

To remove:

1. Remove the face cover and bed cover (Refer to pages 4 and 5).
2. Remove the setscrews ① (2 pcs.).
3. Loosen the setscrew ②.
4. Loosen the setscrew ③.
5. Loosen the setscrew ④.
6. Remove the setscrew ⑤.
7. Disengage the front cover and rear cover hooks.
8. Remove the front cover ⑥.
9. Disconnect all the connectors from the circuit board A.

NOTE:

Do not disconnect the connectors by pulling cords. To disconnect, grasp the connector, not the cord.

To attach:

9. Follow the above procedures in reverse. See "PRINTED CIRCUIT BOARD A CONNECTION" (Page 23).

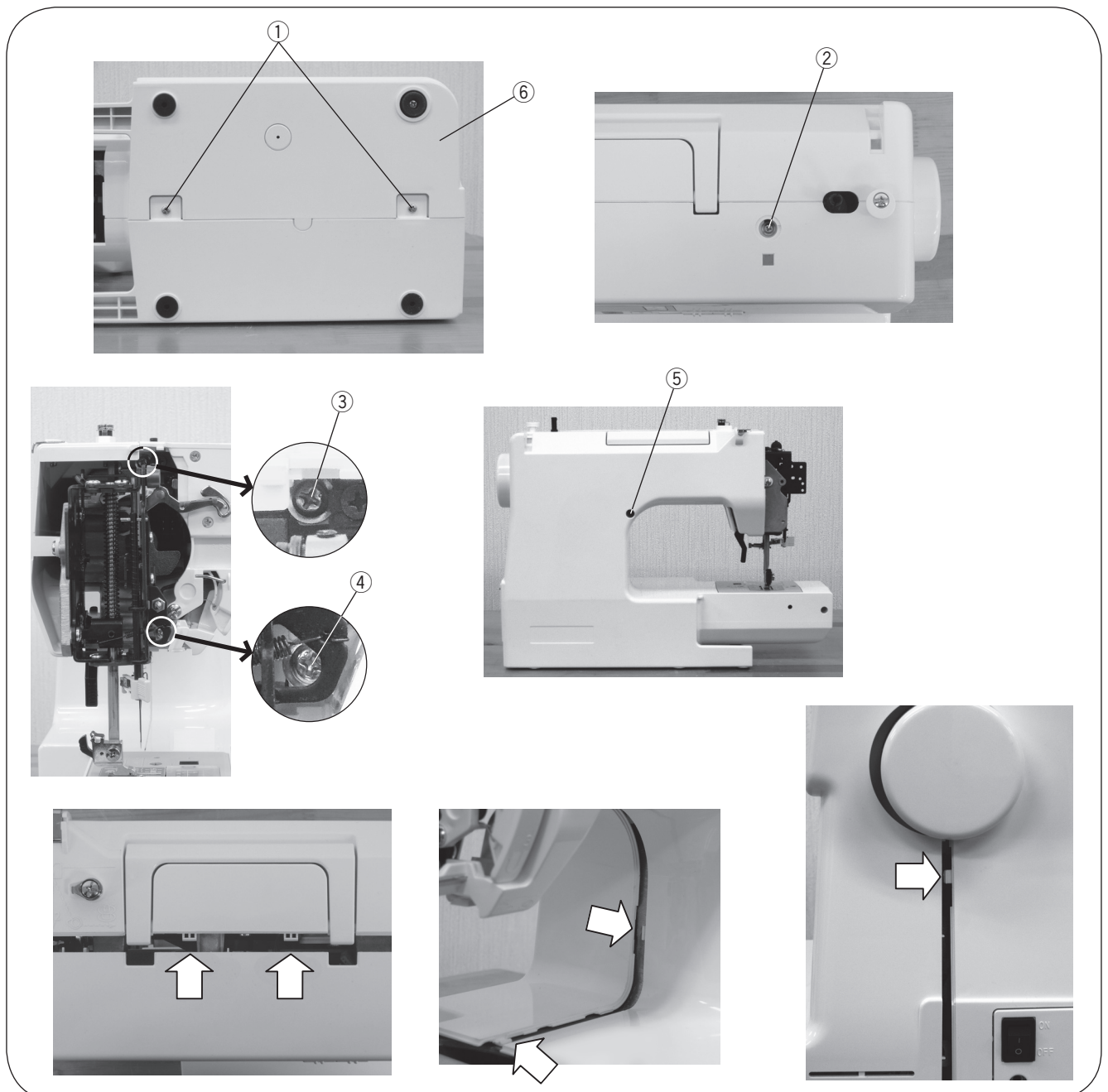

CHANGING EXTERNAL PARTS

REAR COVER

To remove:

1. Remove the face cover, bed cover and front cover (Refer to page 4 to 6).
2. Remove the setscrew ①.
3. Remove the setscrews ② (4 pcs.).
4. Remove the rear cover ③.
5. Disengage the rear cover ③ and thread tension hooks ④.

To attach:

6. Follow the above procedures in reverse.

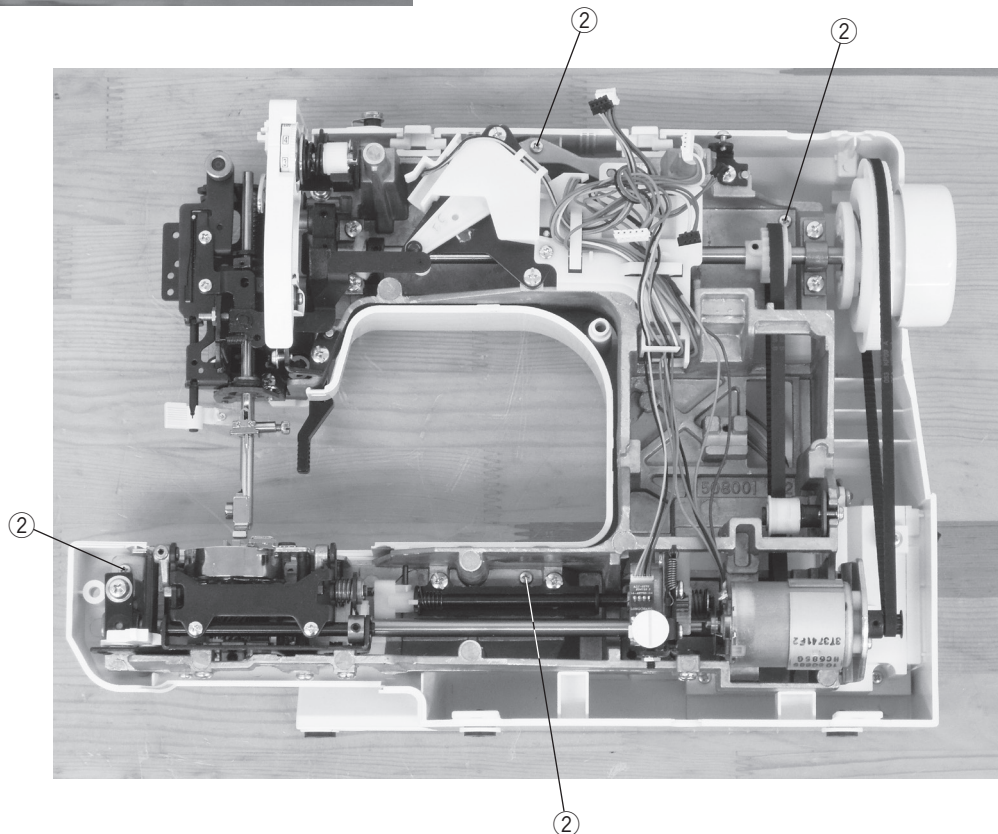
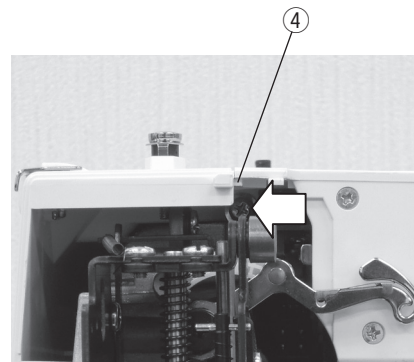

MECHANICAL ADJUSTMENT

PRESSER BAR HEIGHT

The distance between the bottom of the presser foot in up position and the needle plate should be 6.0 mm.

1. Remove the face plate and needle.
2. Lower the feed dog below the needle plate.
Place 6 mm thick block under the presser foot and lower the presser foot lifter.
3. Loosen the hexagonal socket screw. Raise the presser foot lifter and tighten the setscrew firmly.
Attach the needle and face plate.

NOTE:

Make sure that the presser foot should be parallel to the feed dog slots in the needle plate.

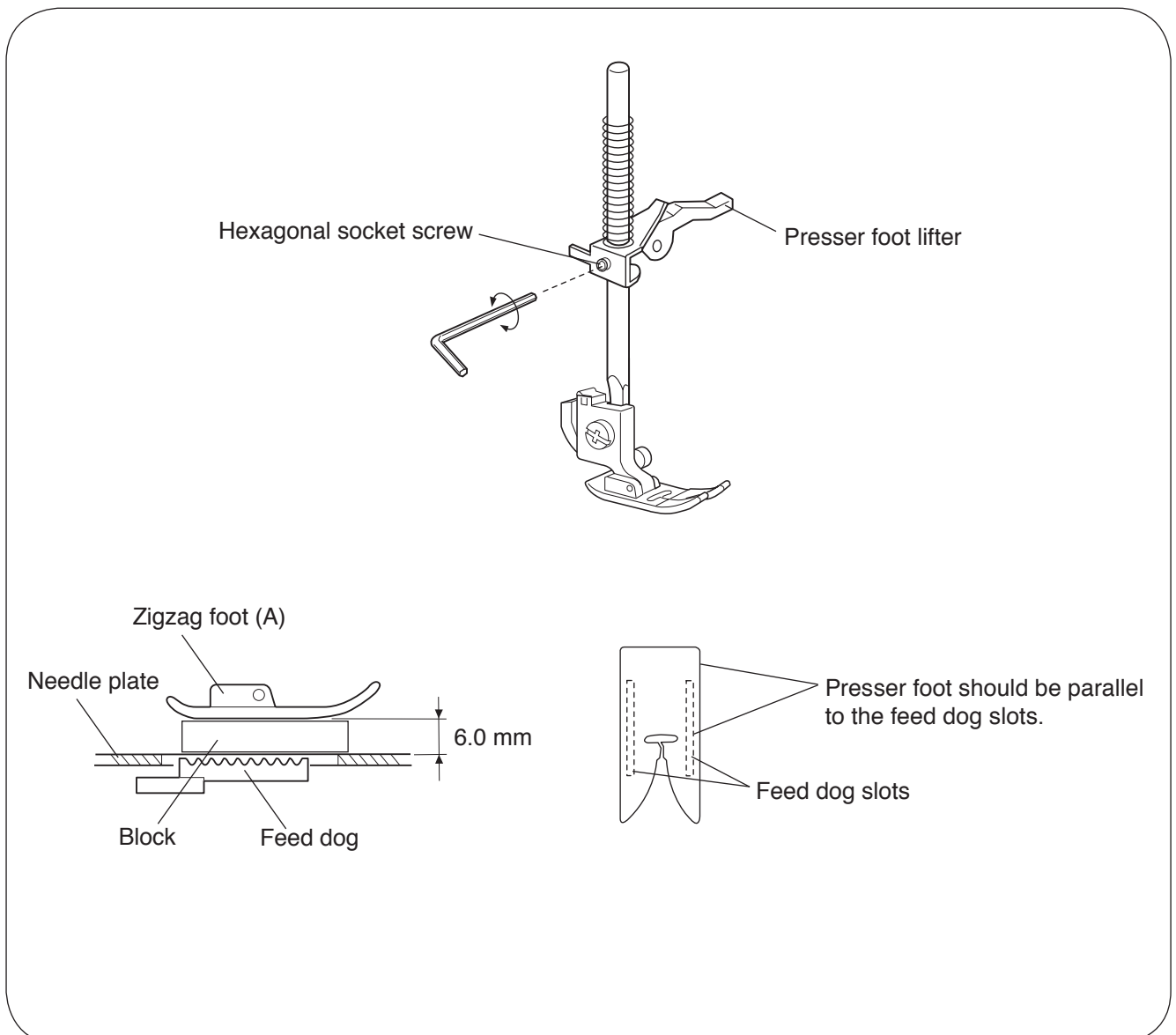

MECHANICAL ADJUSTMENT

NEEDLE DROP POSITION

Select the zigzag stitch .

Set the stitch width to "5.0".

The clearance between the needle drop position and the edge of needle should be 0.2 mm or more for both sides.

If not, make the adjustment as follows:

1. Turn the power switch on.
2. Remove the face cover.
3. Set the stitch width to "5.0".
4. Make the following adjustments if the clearance between the needle drop position and the edge of the needle are even for both sides.
 - * Turn the setscrew clockwise (in the direction of A) if the clearance on the right side of the needle plate hole is smaller than 0.2 mm.
 - * Turn the setscrew counter clockwise (in the direction of B) if the clearance on the left side of the needle plate hole is smaller than 0.2 mm.

NOTE:

Check the hook timing after this adjustment.

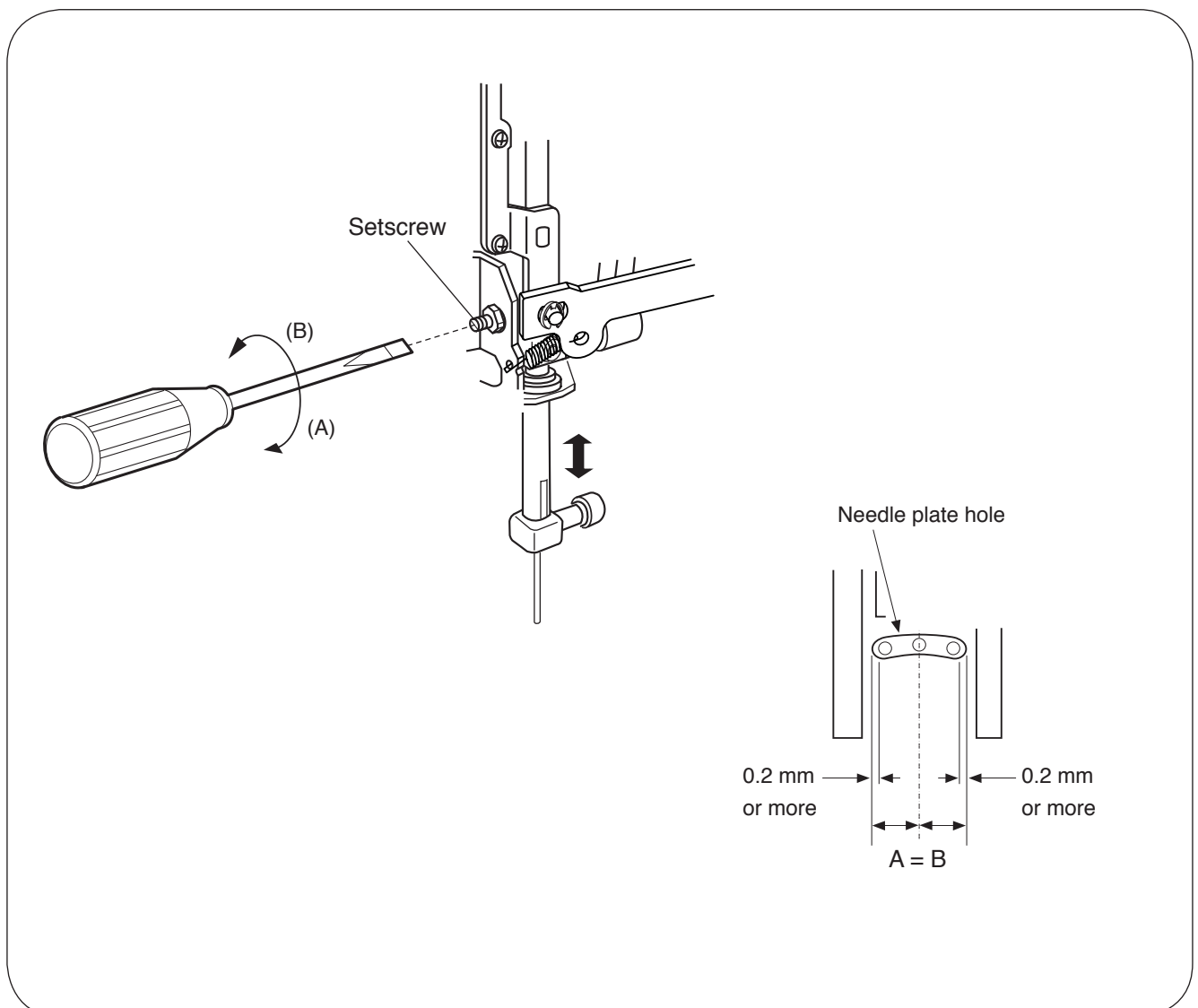

MECHANICAL ADJUSTMENT

ADJUSTMENT OF HOOK TIMING

Select the zigzag stitch .
Set the stitch width to "5.0".

The amount of ascending travel of the needle bar from its lower position to the position where the tip of the rotary hook exactly meets the right side of the needle should be 1.4 to 2.0 mm.

1. Remove the bed cover (Refer to page 5).
2. Select the zigzag stitch .
Set the stitch width to "5.0".
Bring the needle at right lowest needle position.
3. Remove the setscrew on the needle plate, the needle plate and the bobbin holder.
4. Loosen the hexagonal socket screws on the lower shaft gear.
5. Turn the handwheel toward you to raise the needle bar 1.7 mm from its right lowest position.
6. While holding the handwheel to prevent the needle bar from moving, turn the lower shaft gear in the direction of arrow until the tip of the rotary hook exactly meets the right side of the needle.
7. Tighten the hexagonal socket screws on the lower shaft gear.
8. Attach the bobbin holder, needle plate and bed cover.

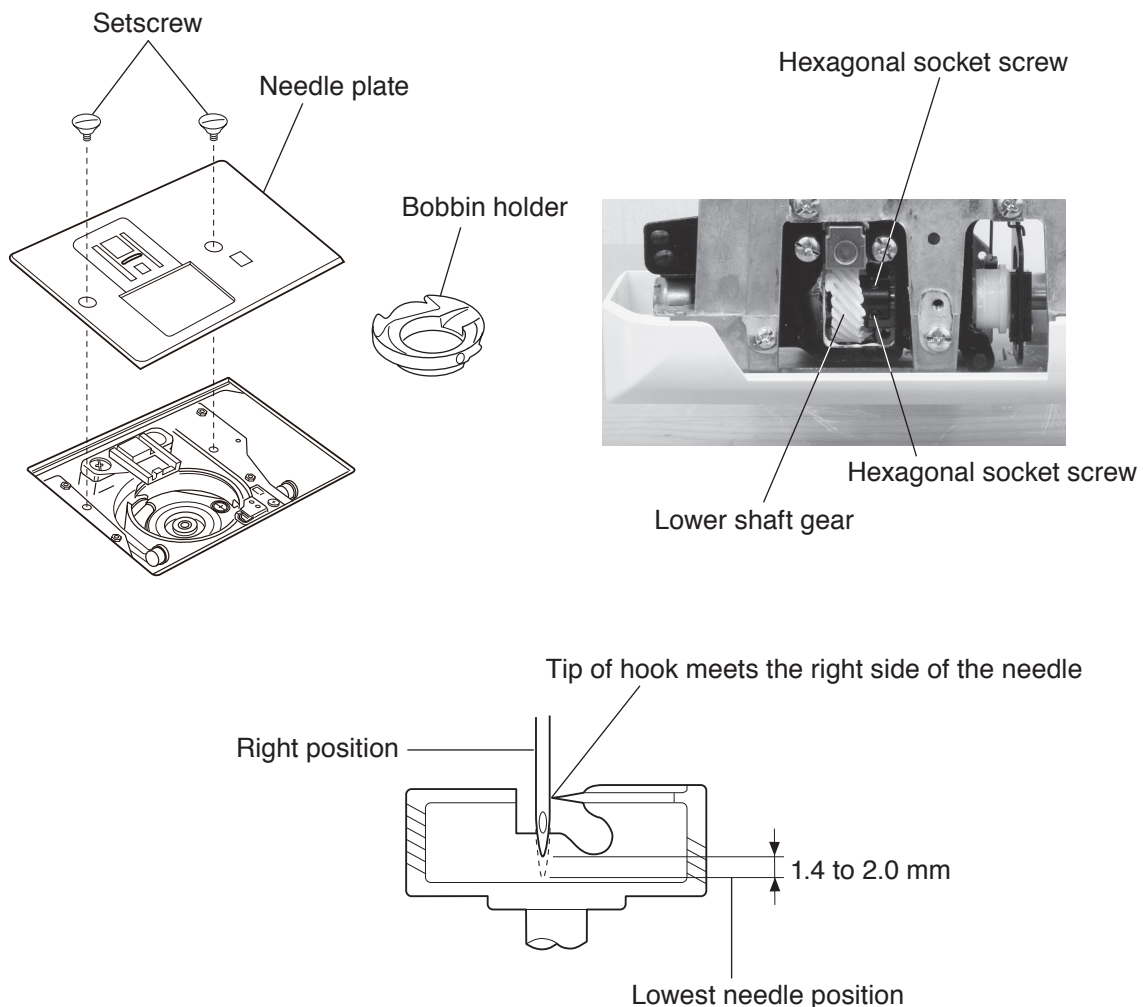

MECHANICAL ADJUSTMENT

ADJUSTMENT OF NEEDLE BAR HEIGHT

The standard distance between the upper edge of the needle eye and the upper surface of the hook race should be in the range of 3.0 to 3.6 mm when the hook point meets the right side of the needle in its ascending travel from right lowest position of the maximum width zigzag stitch.

1. Remove the face cover and bed cover (Refer to pages 4 to 5).
2. Turn the power switch on.
Select the zigzag stitch , and set the stitch width to "5.0".
Bring the needle to the right lowest position.
3. Remove the needle plate and bobbin holder.
4. Turn the handwheel toward you until the hook point meets the right side of the needle.
5. Loosen the hexagonal socket screw and move the needle bar up or down to adjust the needle height.
6. Tighten the hexagonal socket screw.
7. Attach the bobbin holder, needle plate and face cover and bed cover.

NOTE:

Before performing this adjustment, check the needle to hook timing.

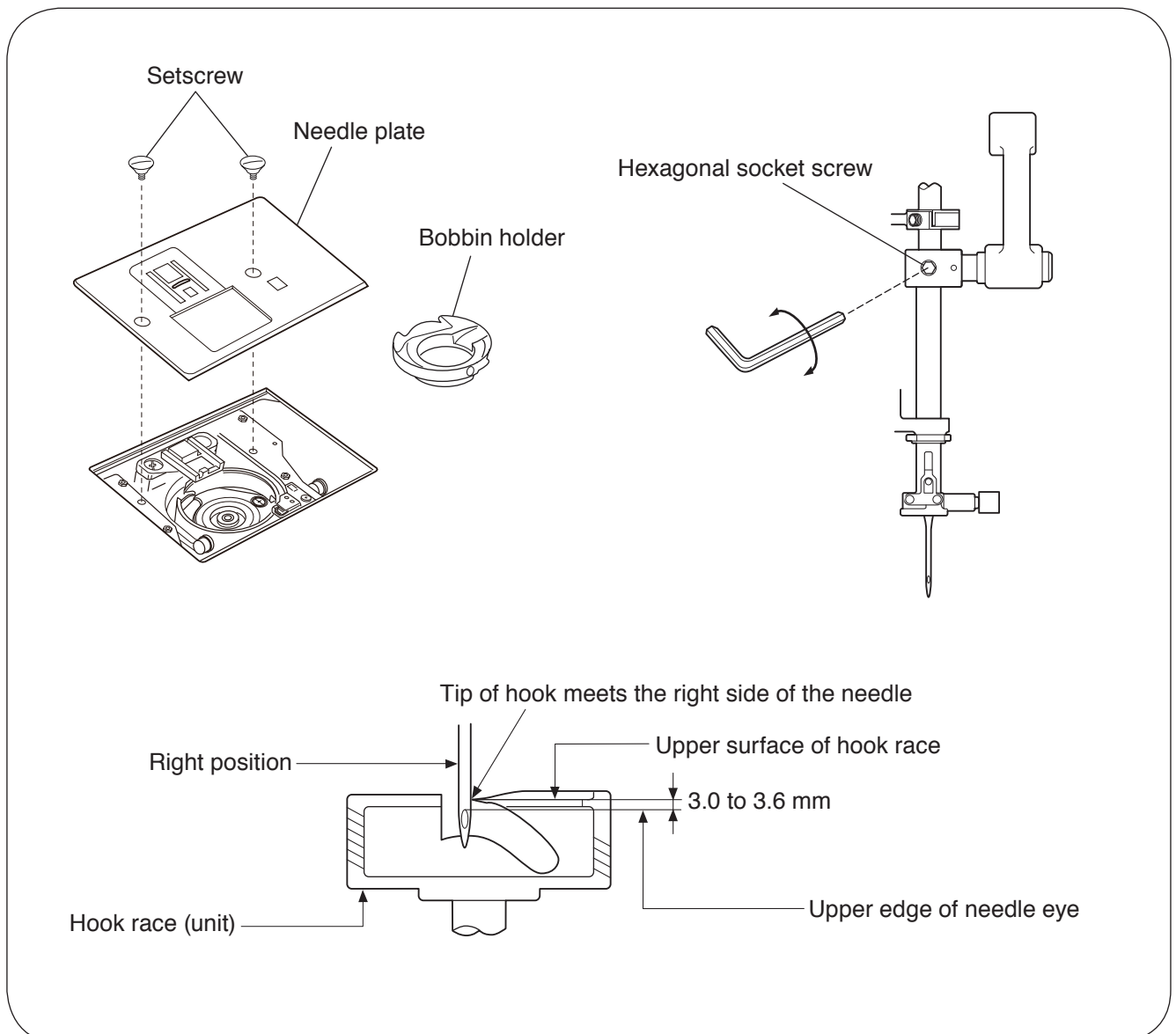

MECHANICAL ADJUSTMENT

CLEARANCE BETWEEN NEEDLE AND TIP OF THE ROTARY HOOK

* The clearance between the needle and the point of hook should be -0.10 to $+0.05$ mm.

Adjustment procedure:

1. Remove the face cover. (Refer to page 4).
2. Remove the needle plate and bobbin holder.
Attach the master needle.
Turn the power switch on.
Select the zigzag stitch zigzag , and set the stitch width to "5.0".
3. Remove the needle plate and bobbin holder. Replace the needle with the master needle and tighten the needle clamp screw.
4. Loosen the setscrews A (2 pcs.) and move the presser bar base plate in the direction of the arrows (B or C).
* Move the presser bar base plate in the direction of B when the clearance is too large.
* Move the presser bar base plate in the direction of C when the clearance is too small.
Adjust the clearance between the needle and hook between -0.10 to $+0.05$ mm. Tighten the setscrews.
* The edge of presser bar base plate should always touches the bosses while adjusting the clearance it.
5. Attach the bobbin holder and needle plate. Attach the face cover.

NOTE:

Be sure that the clearance between the needle drop position and the edge of needle should be 0.2 mm more for both sides (Refer to page 9).

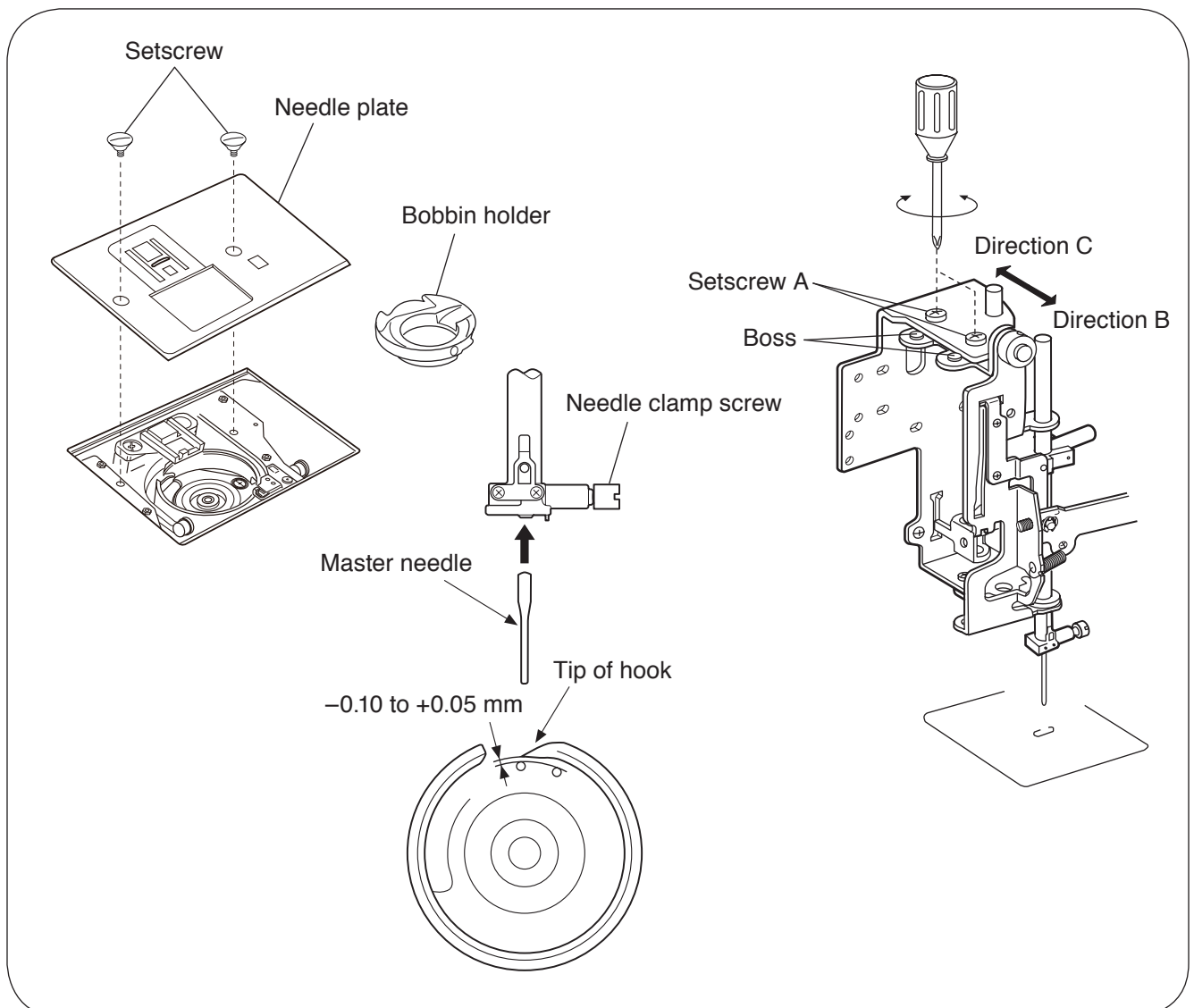

MECHANICAL ADJUSTMENT

FEED DOG HEIGHT

The highest position of the feed dog should be 0.80 to 0.95 mm from the surface of the needle plate.

To check:

1. Lower the presser foot.
2. Turn the handwheel toward you to raise the feed dog at its highest position.
The distance between the feed dog and the upper surface of the needle plate should be 0.80 to 0.95 mm.
If it is not in the range, adjust as follows.

To adjust:

3. Loosen the screw A.
4. Turn the handwheel to bring the feed dog to its highest position.
5. If the feed dog height is lower than 0.80 mm: turn adjusting screw B in the direction of C.
6. If the feed dog height is higher than 0.95 mm: turn the adjusting screw B in the direction of D.
7. Tighten the screw A

Upper surface of the needle plate

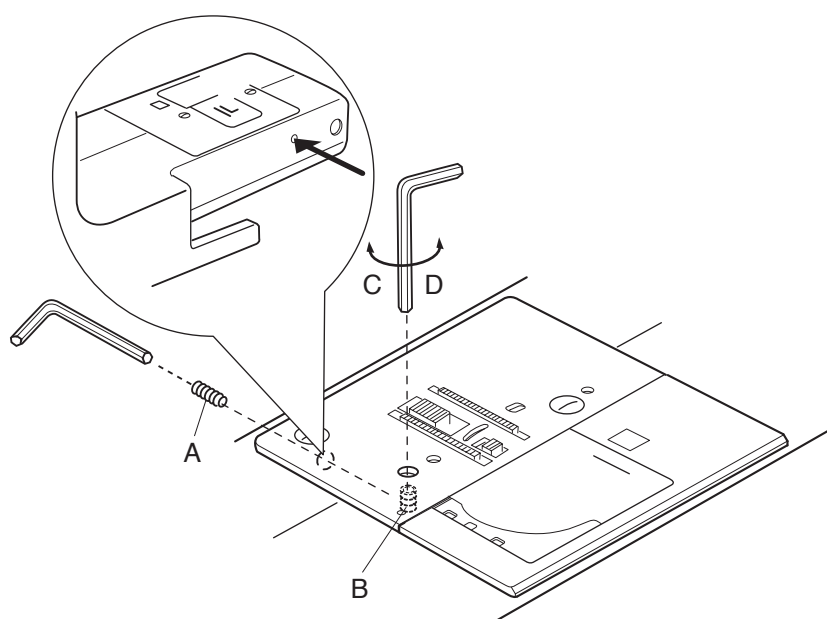
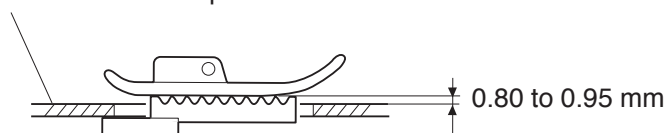

MECHANICAL ADJUSTMENT

BACKLASH BETWEEN HOOK GEAR AND LOWER SHAFT GEAR

The rotary play of the hook point should be 0.8 mm or less when it is in between the span of the feed dog teeth, and the gears should turn smoothly.

1. Remove the needle plate and bobbin holder.
2. Remove the bed cover (Refer to page 5).
3. Loosen the setscrew A.
 - * If the rotary play is too large, turn the lower shaft bussing in the direction of B.
 - * If the rotary play is too small, turn the lower shaft bussing in the direction of C.
4. Tighten the setscrew A.
5. Attach the front cover.
6. Attach the bobbin holder and needle plate.

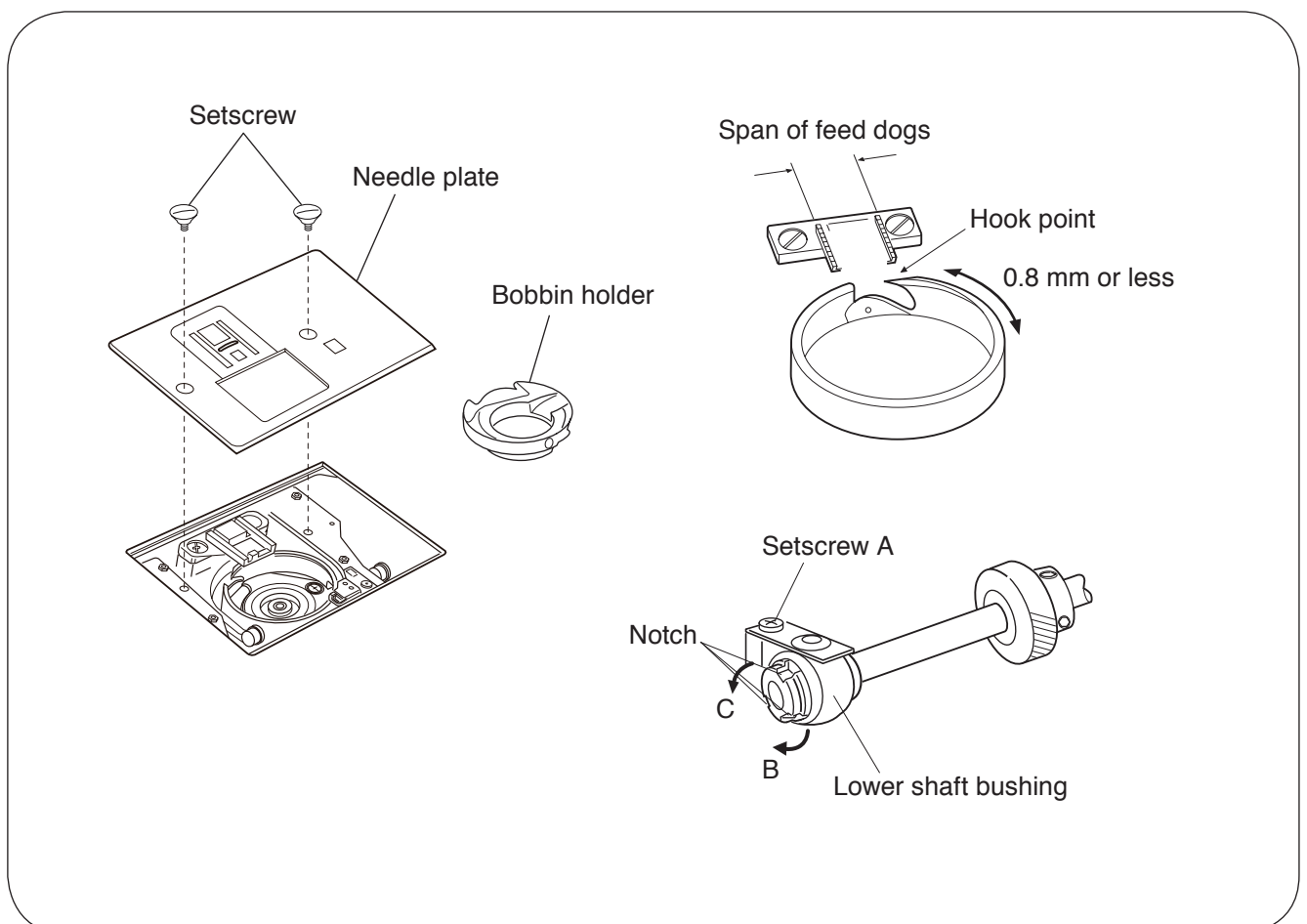

MECHANICAL ADJUSTMENT

TOP TENSION

The top tension should be between 75 to 90 gf when pulling the thread (polyester sewing thread #50 (white)) up in the direction of arrow (Make sure the the foot is lowered) with the tension dial at "4".

If the tension is out of the range, adjust as follows:

1. Remove the front cover (refer to page 6).
2. Set the tension dial at "4".
3. After threading the upper thread, lower the presser foot.
 - If the top tension is too tight, turn the lead screw in the direction A.
 - If the top tension is too loose, turn the lead screw in the direction B.
4. Check the top tension and attach the front cover.

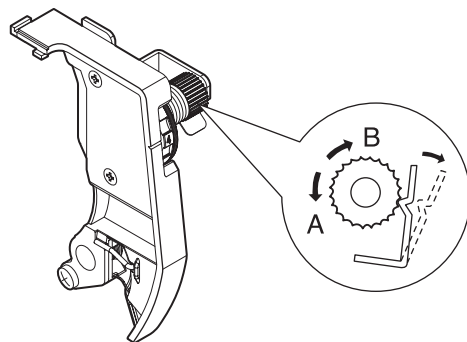

Pull the thread at the speed of 110 mm/sec in the direction of arrow.

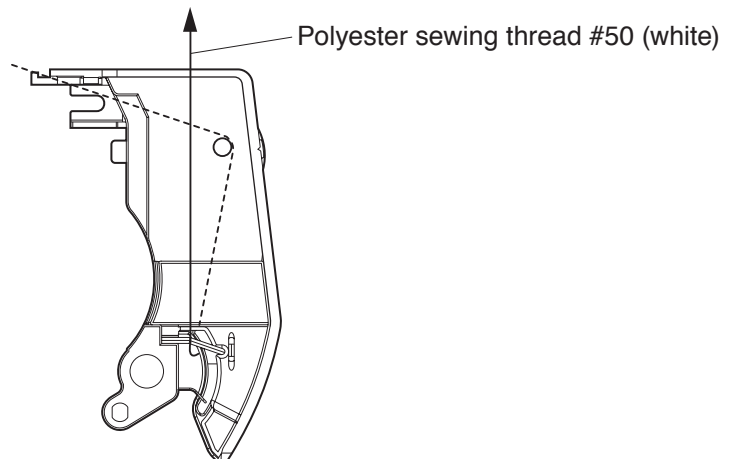

MECHANICAL ADJUSTMENT

STRETCH STITCH FEED BALANCE

To check:

1. Turn the power switch on.
Be sure the feed balancing dial is set at standard position as shown below.
2. Select the triple stitch “” (stitch pattern #05).
3. Sew the 15 pieces of triple stitch as shown below.
Be sure that the total stitch length from the 3rd piece to 13th piece is within the range of 25 to 27 mm.
If not, adjust as follows;

To adjust:

4. Remove the cap.
 - Turn the hexagonal socket screw in the direction of (A) if the total length of 10 pieces of the triple stitch pattern is shorter than 25 mm.
 - Turn the hexagonal socket screw in the direction of (B) if the total length of 10 pieces of the triple stitch pattern is longer than 27 mm.
5. Sew the triple stitch 15 pieces again after the adjustment.
Be sure that the total stitch length from the 3rd piece to 13th piece is within the range of 25 to 27 mm.
Attach the cap.



Turn the power switch on.

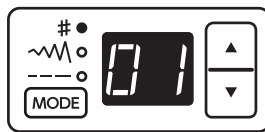

The LED display will indicate “01”.

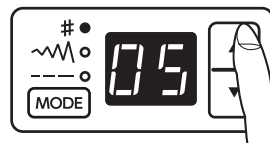

Press the stitch length adjusting key 4 times to display the “05”.

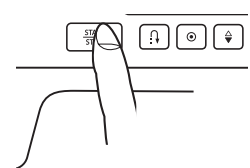

Press the start/stop button.

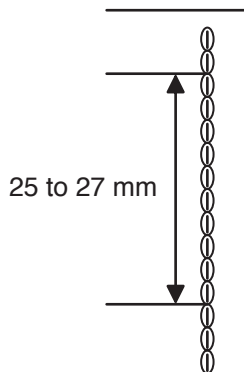

Sew the triple stitch 15 pieces again after the adjustment.

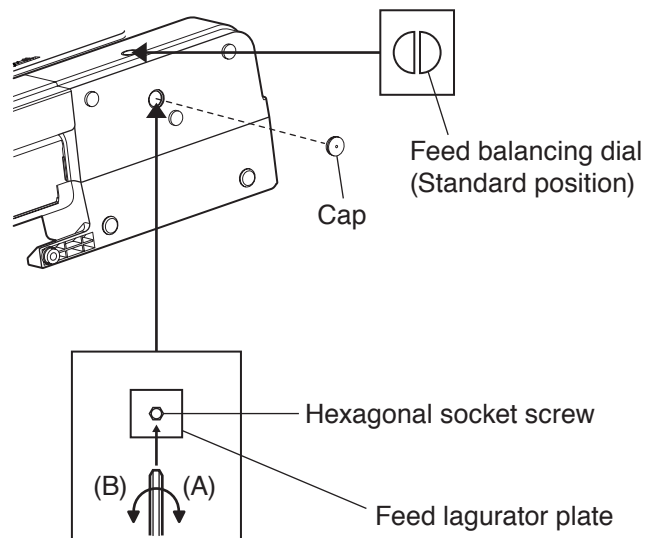

MECHANICAL ADJUSTMENT

REPLACEMENT AND ADJUSTMENT OF THE NEEDLE THREADER PLATE

If the hook of the threader plate is damaged, change and adjust the part as follows:

TO CHANGE THE THREADER PLATE:

1. Push down the needle threader knob and pull the threader plate supporter down to remove it (see FIG 1).
2. To install the needle threader plate, line the groove up with the pin and push it up to snap fit.

TO ADJUST THE THREADER PLATE POSITION:

3. If the hook on the threader positioning plate touches the top or bottom side of the needle hole, loosen hexagonal socket screw and adjust the hook position (FIG.2).
4. If the hook on the threader plate touches the left or right side of the needle hole, loosen setscrew and adjust the hook position (FIG 3).

FIG. 1

Replacing the threader plate supporter
(with the threader plate attached)

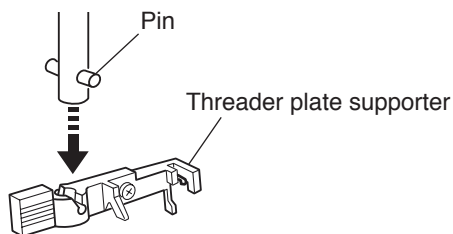
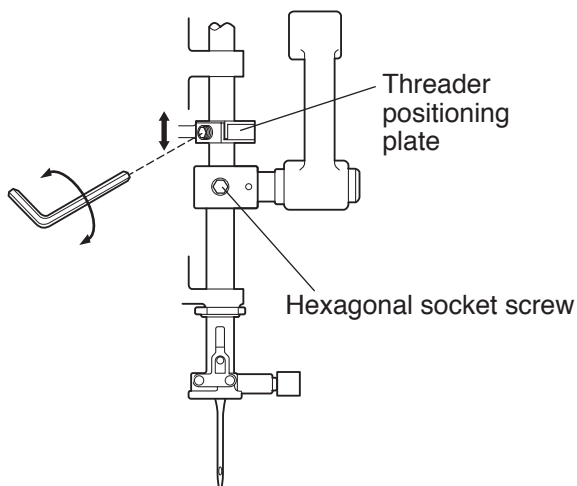

FIG. 1

Vertical adjustment



Adjustment of left or right direction

View from "X"

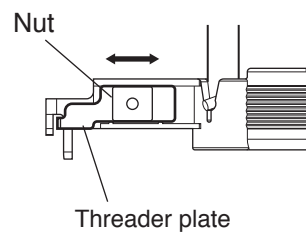
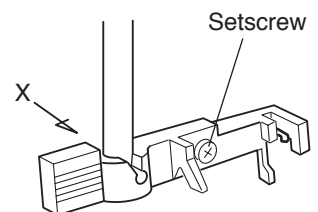

FIG. 3



SELF-DIAGNOSTIC TEST

Preparation:

1. Turn the power switch off.
2. Move the bobbin winder spindle to the left.
3. Raise the feed dog.
4. Set the speed control lever to the left.
5. Remove the presser foot and raise the presser foot lifter.
6. Turn the hand wheel toward you to raise the needle to its highest position.

NOTE:

- Be careful: the sewing machine may start running in its own while in test mode.
- Turn off the power switch before replacing any parts.
- Repeat the diagnostic test until the problem has been resolved.

To begin:

Turn on the switch. If any of the following problems occur, take the recommended actions in the order they are shown.

1. The machine does not respond when the power switch is turned on:
 - Check each connector connection.
 - Replace the switching regulator (with the machine socket).
 - Replace the printed circuit board A.
2. The sewing machine lamp does not light up:
 - Be sure all connectors are connected to the circuit board L and A properly (Refer to page 23).
 - Replace the printed circuit board L.
 - Replace the printed circuit board A.

TO ENTER SELF-DIAGNOSTIC MODE:

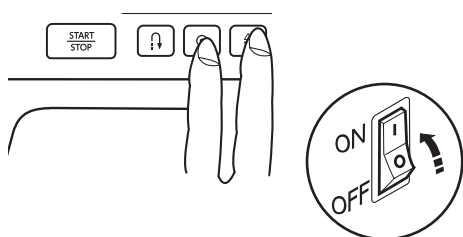

1. Turn the power switch on while simultaneously pressing auto-lock button and needle up/down button.

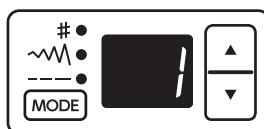



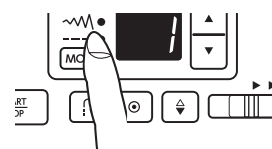

2. The LED display will indicate " 1".

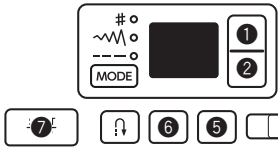
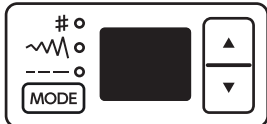
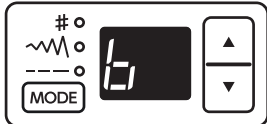

3. Press the MODE key to enter the self-diagnostic mode.

SELF-DIAGNOSTIC TEST

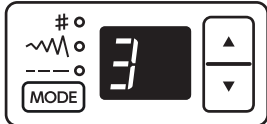
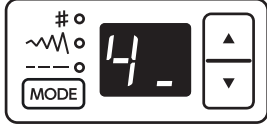
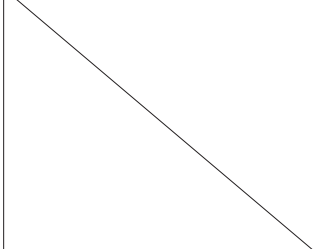
STEP AND ITEMS TO CHECK	PROCEDURE	CORRECT CONDITION	DEFECTIVE CONDITION
<p>01) FUNCTION OF LED, BUZZER AND LAMP</p>	<p>Turn on the power switch while simultaneously pressing the auto-lock button and needle up/down button.</p> <p>Press the MODE key to enter the self-diagnostic mode.</p> <p>If the result is correct condition, press the MODE key to proceed the next step.</p> <p>If the result is defective condition, press the reverse stitch button to proceed the next step.</p>	<p>Sewing lamp and LED backlight lit. LED displays " 1".</p> <p>Press the MODE key.</p>  <p>Buzzer sounds. LED displays "8.8" as shown.</p> <p>Three indicator lights are on.</p> 	<p>Sewing lamp does not lit. LED backlight does not lit. LED does not display. Buzzer does not sound. LED does not turned on. LED does not display any symbols or not in order.</p> <p>-REMEDY- Replace the circuit board A. Replace the circuit board L.</p>
<p>02) BUTTON</p>	 <p>Press buttons 1, 2, 5, 6 and 7.</p> <p>If the result is correct condition, press the MODE key to proceed the next step.</p> <p>If the result is defective condition, press the reverse stitch button to proceed the next step.</p>	<p>LED displays nothing.</p> <p>Buzzer sounds when button is pressed.</p> <p>Button number is displayed when the following buttons are pressed.</p>  <p>LED displays " 1" when button ① is pressed. LED displays " 2" when button ② is pressed. LED displays " 5" when button ⑤ is pressed. LED displays " 6" when button ⑥ is pressed. LED displays " 7" when button ⑦ is pressed.</p> <p>When ① - ⑦ are pressed, LED displays "b " as shown.</p> 	<p>Buzzer does not sound. LED does not display the number correctly.</p> <p>-REMEDY- Replace the circuit board A.</p>
<p>03) BOBBIN WINDER SWITCH</p>	<p>Move the bobbin winder spindle to the right. Return it to the left.</p> <p>If the result is correct condition, press the MODE key to proceed the next step.</p> <p>If the result is defective condition, press the reverse stitch button to proceed the next step.</p>	<p>LED displays "3 ".</p> <p>When the bobbin winder spindle is moved to the right, buzzer sounds and LED displays the 3S as shown.</p>  <p>When the bobbin winder spindle is moved to the left, buzzer sounds and S disappears.</p> 	<p>Buzzer does not sound. Bobbin symbol is not displayed.</p> <p>-REMEDY- Adjust the bobbin winder switch position. Replace the bobbin winder switch. Replace the circuit board A.</p>
<p>04) PRESSER FOOT LIFTER SWITCH</p>	<p>Not applicable for this model.</p> <p>Press the MODE key to proceed the next step.</p>	<p>LED displays "4_".</p> <p>The under bar is displayed as shown.</p> 	

SELF-DIAGNOSTIC TEST

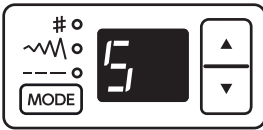
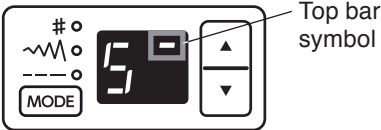
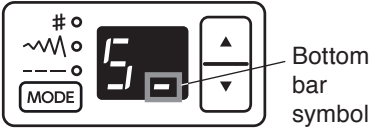
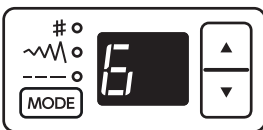
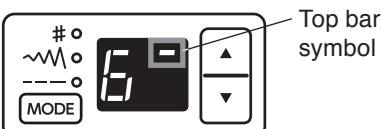
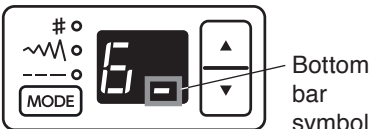
STEP AND ITEMS TO CHECK	PROCEDURE	CORRECT CONDITION	DEFECTIVE CONDITION
<p>05) UPPER SHAFT POSITIONING SENSOR</p>	<p>Turn the handwheel toward you. Lower the needle bar from its highest to lowest position. Raise the needle bar from its lowest position to highest position.</p> <p>If the result is correct condition, press the MODE key to proceed the next step.</p> <p>If the result is defective condition, press the reverse stitch button to proceed the next step.</p>	<p>LED displays "5".</p>  <p>Turn the handwheel.</p> <p>LED displays the top bar symbol when the needle bar is at zigzag phase.</p>  <p>LED displays needle lowest position symbol when the needle bar is at feed phase.</p> 	<p>Buzzer does not sound. Stitch width or length symbol does not appear.</p> <p>–REMEDY– Replace the circuit board A.</p>
<p>06) ZIGZAG MOTOR (STEP MOTOR) AND FEED MOTOR</p>	<p>Turn the handwheel toward you. Lower the needle bar to its lowest position (zigzag phase). Press the needle up/down button.</p> <p>Raise the needle bar from its lowest position to its highest position (feed phase). Press the needle up/down button.</p> <p>If the result is correct condition, press the MODE key to proceed the next step.</p> <p>If the result is defective condition, press the reverse stitch button to proceed the next step.</p>	<p>LED displays "6".</p>  <p>Press the needle up/down button when LED displays top bar symbol. The Zigzag motor will be initialized and get its default position. Press the needle up/down button</p>  <p>when LED displays bottom bar symbol. The feed motor will be initialized and get its default position.</p> 	<p>Zigzag motor does not get default position. Buzzer does not sound.</p> <p>–REMEDY– Replace the zigzag motor. Replace the circuit board A. Feed motor does not get default position. Buzzer does not sound.</p> <p>–REMEDY– Replace the zigzag width motor. Replace the feed motor. Replace the circuit board A.</p>

SELF-DIAGNOSTIC TEST

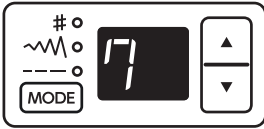
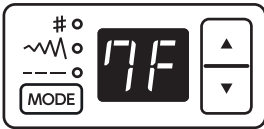
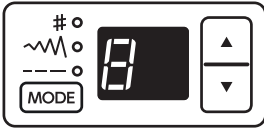
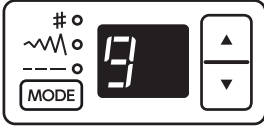
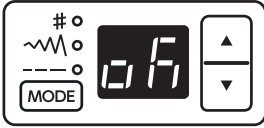
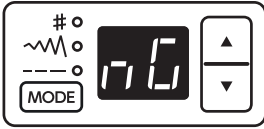
STEP AND ITEMS TO CHECK	PROCEDURE	CORRECT CONDITION	DEFECTIVE CONDITION
<p>07) FOOT CONTROL</p>	<p>Attach the foot control to the machine. Depress the foot control as far as it goes, then release it.</p> <p>If the result is correct condition, press the MODE key to proceed the next step.</p> <p>If the result is defective condition, press the reverse stitch button to proceed the next step.</p>	<p>LED displays "7".</p>  <p>The "7F" appears when the foot control is attached.</p>  <p>Buzzer sounds when the foot control is deeply depressed. Buzzer sounds when the foot control is released.</p>	<p>The foot control symbol does not appear. Buzzer does not sound.</p> <p>–REMEDY– Replace the foot control. Replace the switching regulator (foot control socket). Replace the circuit board A.</p>
<p>08) SLIDE VOLUME</p>	<p>Shift the slide volume from left to right, then return to the left.</p> <p>If the result is correct condition, press the MODE key to proceed the next step.</p> <p>If the result is defective condition, press the reverse stitch button to proceed the next step.</p>	<p>LED displays "8".</p>  <p>Buzzer sounds at rightmost or leftmost position.</p>	<p>Buzzer does not sound.</p> <p>–REMEDY– Replace the circuit board A.</p>
<p>09) DC MOTOR</p>	<p>Press the needle up/down button.</p> <p>If the result is correct condition, press the MODE key to proceed the next step.</p> <p>If the result is defective condition, press the reverse stitch button to proceed the next step.</p>	<p>LED displays "9".</p>  <p>Machine runs slow, then fast, and stops.</p> <p>LED displays "OK" when the machine is correct condition.</p>  <p>LED displays "NG" when the machine is defective condition.</p> 	<p>The machine motor does not start. The motor stops immediately. The motor runs unstable.</p> <p>–REMEDY– Replace the DC motor. Replace the circuit board A.</p>

SELF-DIAGNOSTIC TEST

Buzzer sounds after few seconds when the self-diagnostic test has been finished. The test result has been determined.

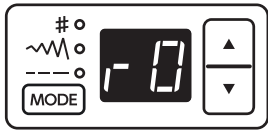

CORRECT:
Buzzer sounds and LED displays “ 0”

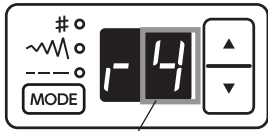

DEFECTIVE:
Caution buzzer sounds and LED displays the defective part number. Refer to pages 19 to 21 and fix the defective part. Each time you press the MODE key, the defective part number(s) will be displayed.

The defective part number.
Refer to pages 19 to 21
“Steps and items” section.

Press the reverse switch button to return to 01.
Turn the power switch off when the self-diagnostic test is finished.

TO DISPLAY THE VERSION OF THE PROGRAM

1. Turn the power switch on while simultaneously pressing auto-lock button and needle up/down button.
2. The LED display will indicate “ 1”.
3. Press the value set key once to display the “ 2”.
4. Press the MODE key to.
5. Each time you press the MODE key, the version number will be partially displayed in sequence. Example: 805A-1-1.00-001

REPLACING THE ELECTRONIC COMPONENTS

PRINTED CIRCUIT BOARD A CONNECTION

NOTE:

Do not disconnect the connectors by pulling on cord.
To disconnect, grasp the connector, not the cord.

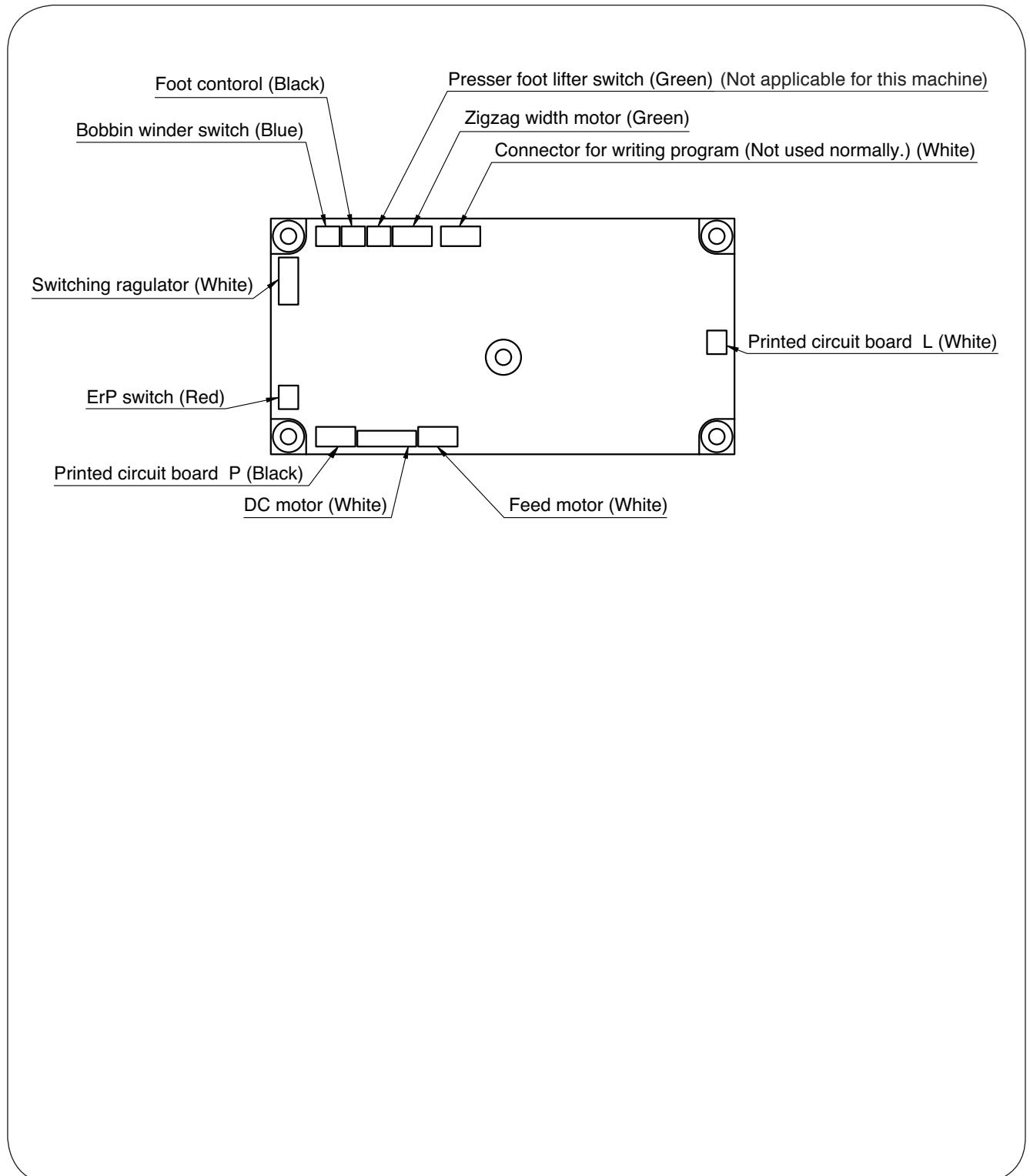

REPLACING THE ELECTRONIC COMPONENTS

PRINTED CIRCUIT BOARD A

TO REMOVE:

1. Remove the front cover. (Refer to page 6.)
2. Pull out connectors from the printed circuit board A.
3. Remove the setscrews (4 pcs.) and the printed circuit board A.

TO ATTACH:

4. Follow the above procedures in reverse.

NOTE:

Do not disconnect the connectors by pulling on cord.
To disconnect, grasp the connector, not the cord.

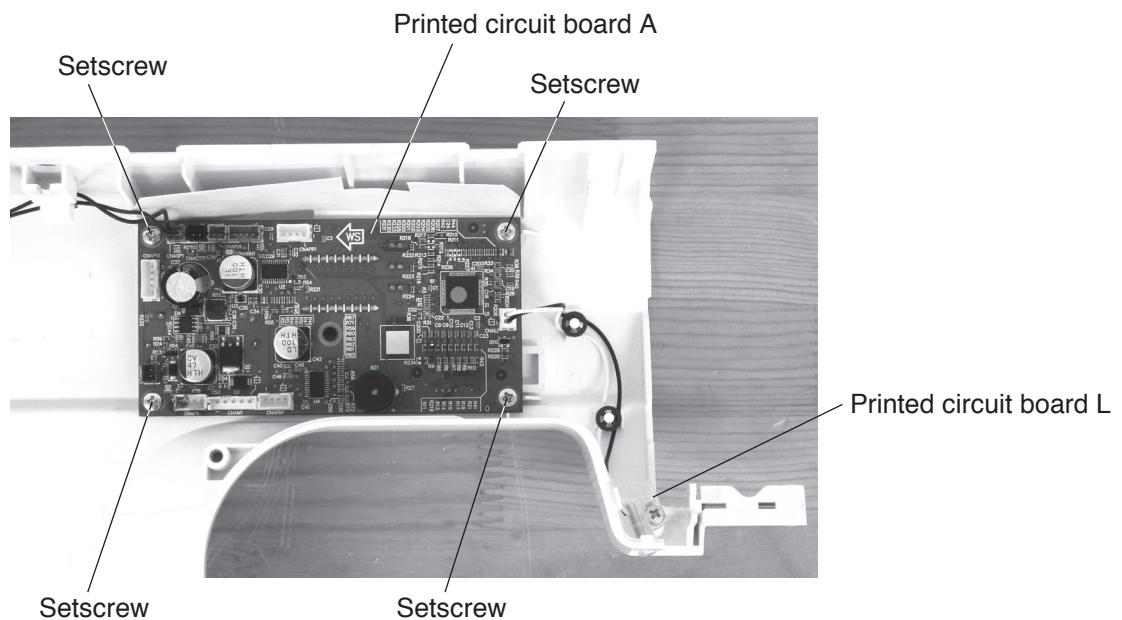

REPLACING THE ELECTRONIC COMPONENTS

PRINTED CIRCUIT BOARD L

TO REMOVE:

1. Remove the front cover. (Refer to page 6.)
2. Pull out connectors from the printed circuit board A.
3. Remove the setscrew and LED cover.
4. Remove the snap rings CS (4 pcs.).
5. Remove the printed circuit board L.

TO ATTACH:

6. Follow the above procedures in reverse.

NOTE:

Do not disconnect the connectors by pulling on cord.
To disconnect, grasp the connector, not the cord.

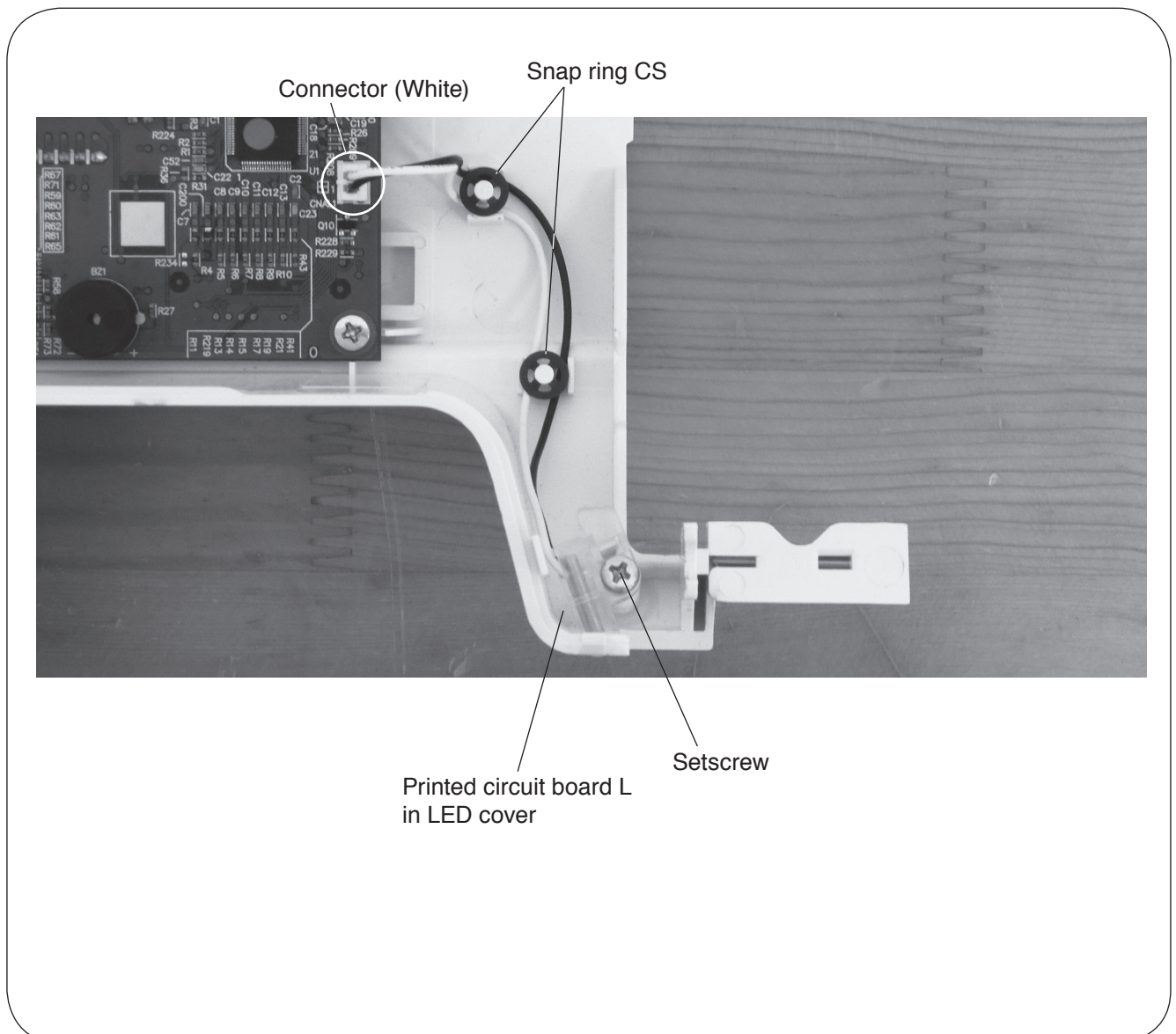

REPLACING THE ELECTRONIC COMPONENTS

DRIVING MOTOR (DC MOTOR)

TO REMOVE:

1. Remove the front cover. (Refer to page 6.)
2. Remove the setscrews (2 pcs.) and the driving motor and the belt.

TO ATTACH:

3. Install the driving motor and the motor belt. Tighten them with setscrews (2 pcs.) lightly.
4. Move the motor up or down to adjust the motor belt tension.
The belt should deflect 7 to 9 mm when applying 300 grams-force of load to the middle of the belt.
Tighten the setscrews (2 pcs.) firmly.
5. Attach the front cover.

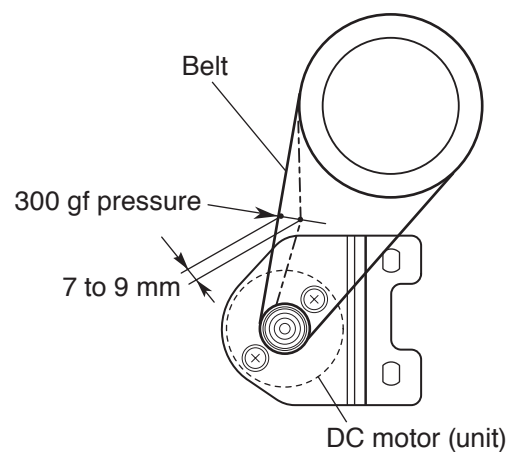
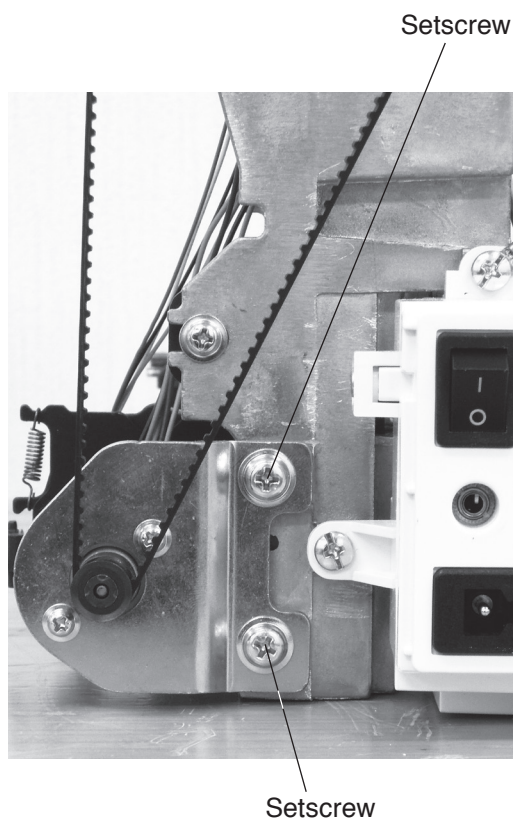

REPLACING THE ELECTRONIC COMPONENTS

SWITCHING REGULATOR UNIT

TO REMOVE:

1. Remove the front cover and the rear cover. (Refer to pages 6 and 7.)
2. Remove the setscrews (3 pcs.) and the switching regulator with cords.

TO ATTACH:

3. Follow the above procedures in reverse.
Be sure to connect the connectors (switching regulator connector (white) and ErP switch connector (Red)) to the circuit board A (Refer to page 23).
* ErP switch (Red) is only for the applicable model.

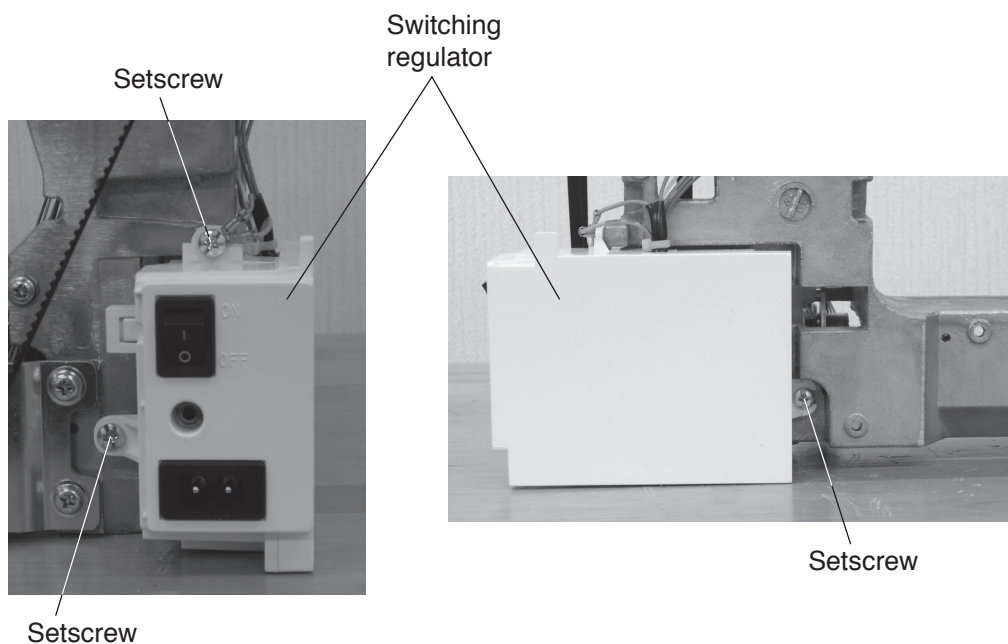

PARTS LIST

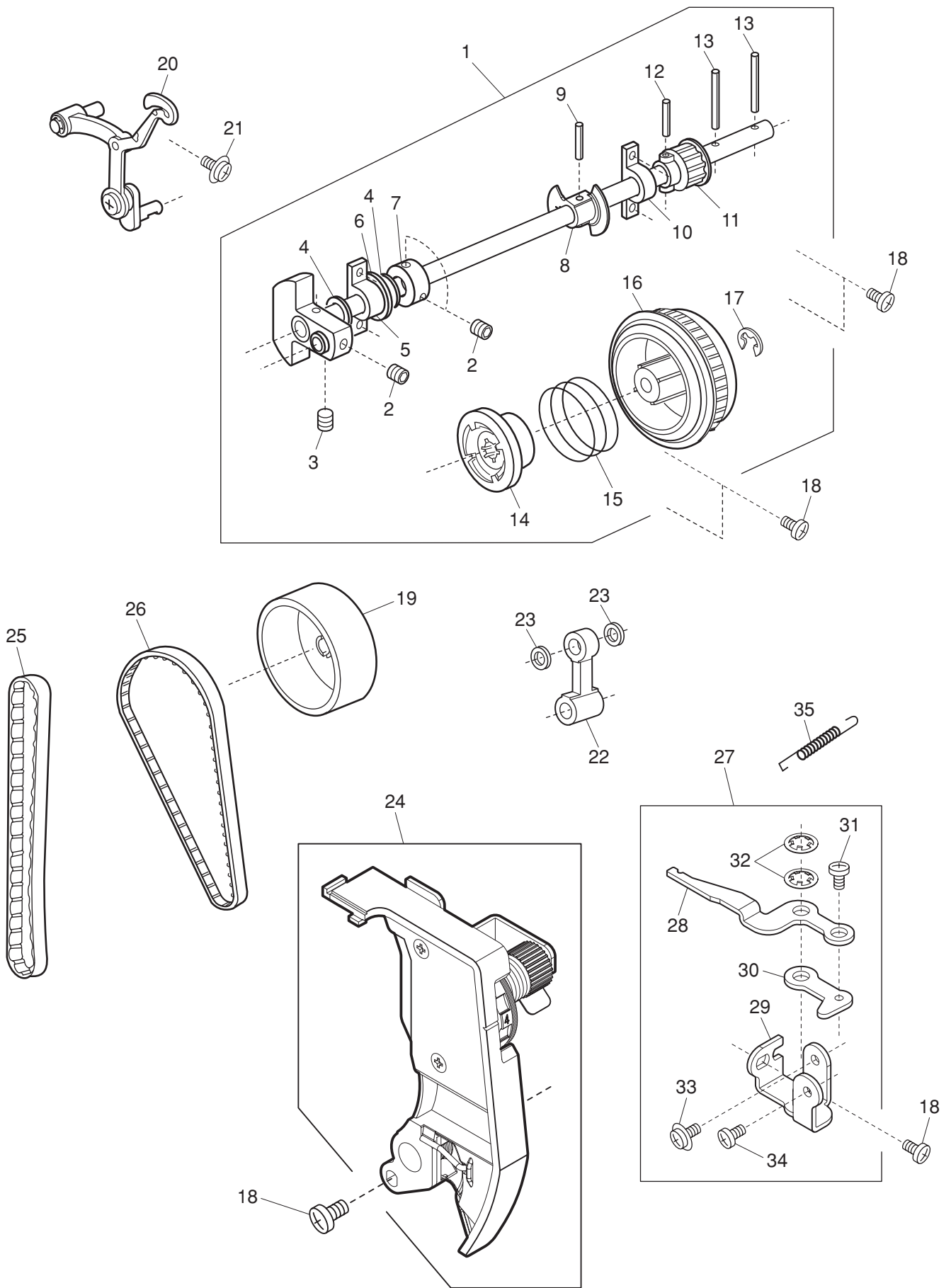

PARTS LIST

KEY NO.	PARTS NO.	DESCRIPTION
1	805601006	Upper shaft (unit)
2	000111201	Hexagonal socket screw 4x4
3	000112800	Hexagonal socket screw 4x6
4	000036201	Washer FT80
5	508120006	Shaft supporter plate
6	823110010	Felt
7	820166001	Lower shaft ring
8	805001000	Upper shaft shielding plate
9	000004107	Spring pin 3x14
10	508054101	Shaft supporter plate
11	508021006	Upper shaft gear
12	000004200	Spring pin 3x18
13	000024206	Spring pin 3x30
14	502064003	Clutch ring
15	661024007	Clutch spring
16	508055009	Belt wheel
17	000002806	Snap ring E-6
18	000081005	Setscrew 4x8
19	508056000	Handwheel
20	508634008	Thread take-up lever (unit)
21	000115700	Setscrew TP 4x10
22	508017009	Needle bar crank rod
23	000036005	Washer FT60
24	805502006	Thread tension (unit)
25	508022007	Syncro belt S5M
26	753234011	Timing belt
27	508617005	Thread tension set plate (unit)
28	508051005	Thread tension set plate
29	508052006	Thread tension release arm
30	639025009	Thread tension release adjusting arm
31	000103808	Setscrew 3x5
32	000013903	Snap ring CS-5
33	000115205	Setscrew TP 4x6
34	810220003	Setscrew
35	639026000	Thread tension release lever spring

PARTS LIST

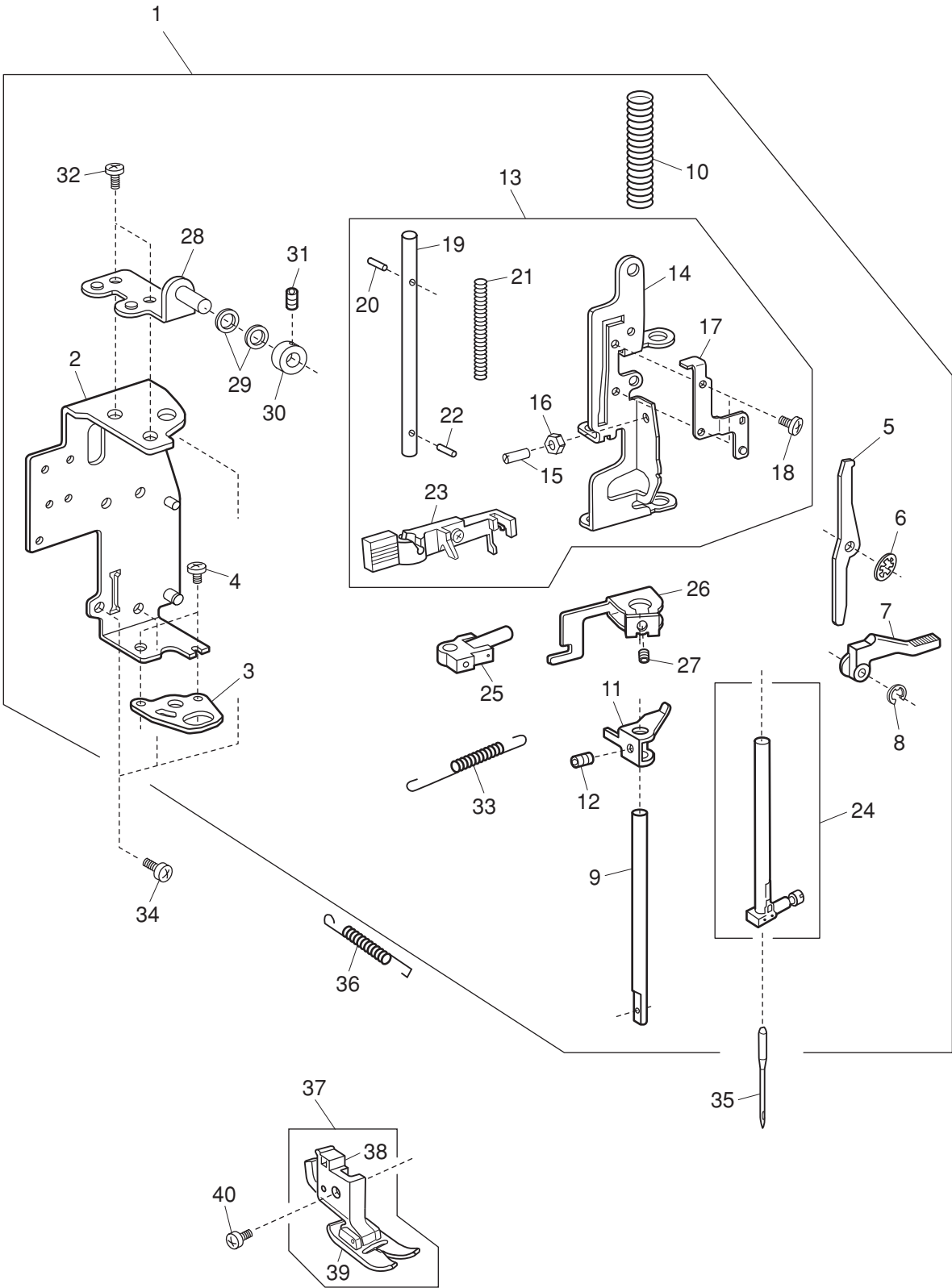

PARTS LIST

KEY NO.	PARTS NO.	DESCRIPTION
1	508640007	Presser bar base plate (unit)
2	508036004	Presser bar base plate
3	508037005	Needle drop adjusting plate
4	000101507	Setscrew 3.5x5
5	508040001	Thread tension release lever
6	000013903	Snap ring CS-5
7	735029004	Presser foot lifter
8	000001609	Snap ring E-5
9	508002001	Presser bar
10	508038006	Presser bar spring
11	508039007	Presser bar supporter
12	000111500	Hexagonal socket screw 4x8
13	508641008	Needle threader (unit)
14	508041002	Needle bar supporter
15	648010009	Setscrew
16	000160102	Adjustable lock nut 4
17	660065007	Zigzag width rod guide
18	000101105	Setscrew 3x4
19	660100201	Threader shaft
20	000122906	Guide pin E-2x14-CH
21	508152007	Threader spring
22	000003508	Spring pin 2x8
23	639643009	Needle threader plate (unit)
24	508607002	Needle bar (unit)
25	508509003	Needle bar connecting stud (unit)
26	808011002	Threader position set plate
27	000111902	Hexagonal socket screw 3x4
28	660068000	Supporter adjusting plate
29	000036500	Washer FT60
30	650136009	Ring
31	000111201	Hexagonal socket screw 4x4
32	000101404	Setscrew 4x6
33	639110002	Needle bar supporter spring 2
34	000081005	Setscrew 4x8
35	102408089	Needle
36	639017008	Needle bar supporter spring
37	660508007	Presser foot (unit)
38	660806008	Presser foot holder (unit)
39	685502019	Zigzag foot (unit)
40	660106001	Setscrew

PARTS LIST

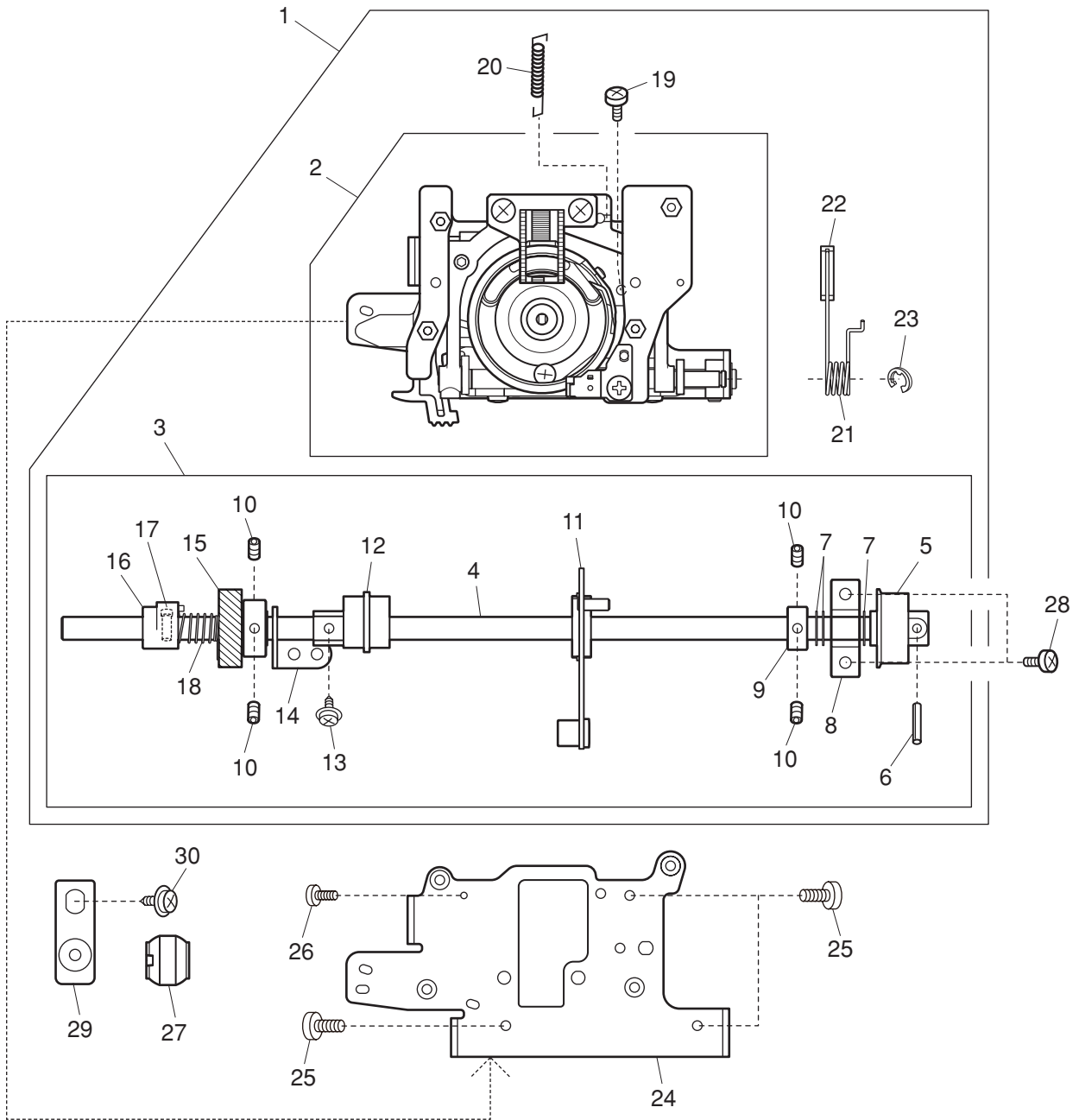

PARTS LIST

KEY NO.	PARTS NO.	DESCRIPTION
1	508636206	Hook race (whole unit)
2	508650000	Hook race (unit)
3	508611308	Lower shaft (unit)
4	508058002	Lower shaft
5	508021006	Upper shaft gear
6	000004200	Spring pin 3x18
7	508146008	Washer
8	508054101	Shaft supporter plate
9	820166001	Lower shaft ring
10	000111201	Hexagonal socket screw 4x4
11	508610008	Feed fork (unit)
12	508200001	Feed cam
13	000115009	Setscrew TP 3x8
14	508098004	Lower shaft supporter plate
15	808137005	Lower shaft gear
16	503165008	Feed lifting cam
17	820161006	Feed lifting pin
18	508113006	Feed lifting cam spring
19	000103705	Setscrew 4x5
20	508063000	Feed base spring
21	508065002	Feed fork spring
22	751152018	Feed fork spring plate
23	000002507	Snap ring E-4
24	508059003	Hook race supporter plate
25	000101703	Setscrew 4x12
26	000081500	Setscrew 3x12
27	732034003	Lower shaft bushing
28	000081005	Setscrew 4x8
29	502204007	Lower shaft bushing set plate
30	000115504	Setscrew TP 5x10

PARTS LIST

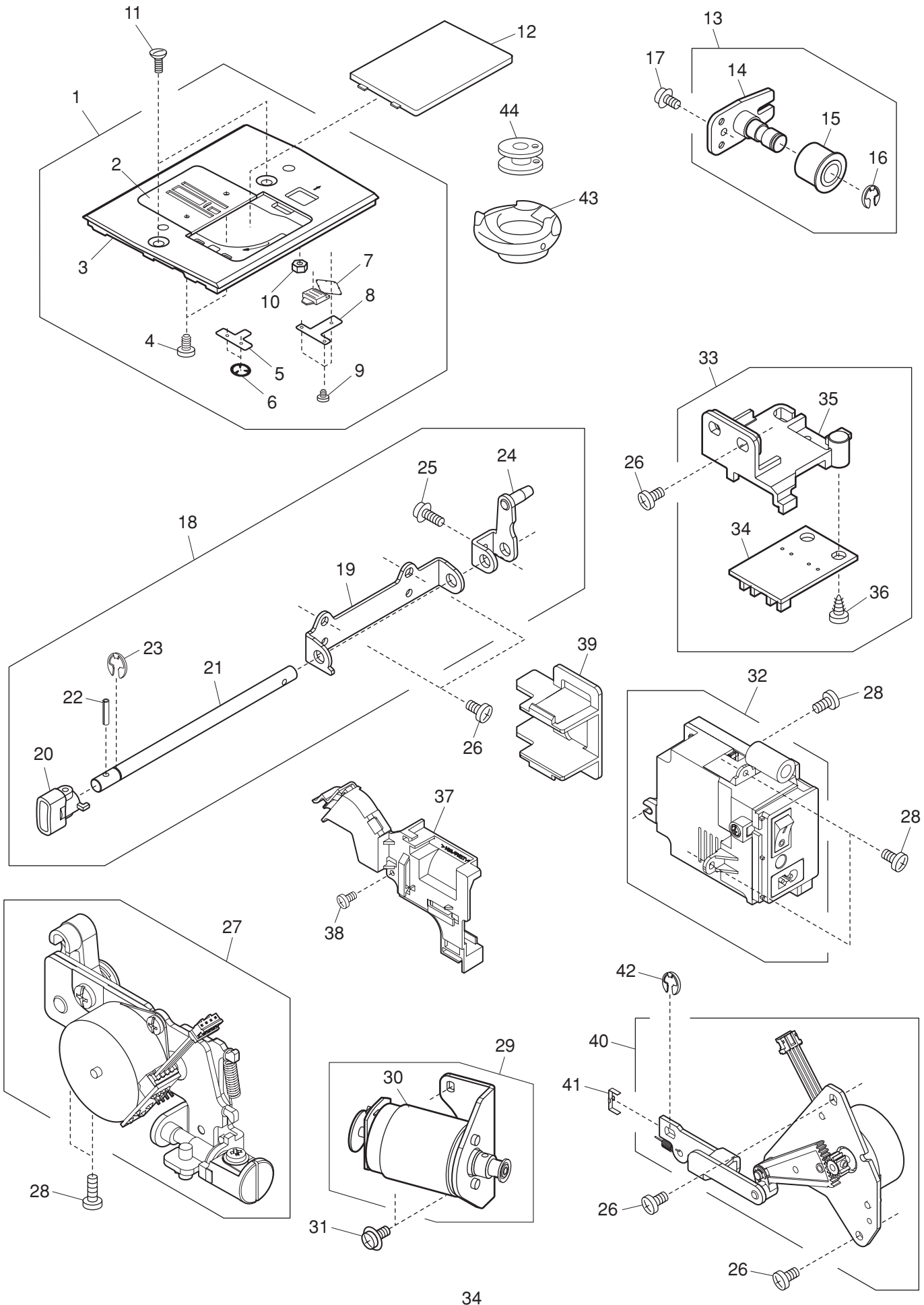

PARTS LIST

KEY NO.	PARTS NO.	DESCRIPTION
1	508612000	Needle plate (unit)
2	508033104	Needle plate
3	508034002	Support needle plate
4	000163703	Setscrew 2x3.5
5	502015009	Spring
6	000015503	Snap ring CS-2.4
7	502016000	Hook cover plate release button
8	502202005	Supporter plate
9	000130206	Setscrew 1.7x2.5 (B)
10	508116009	Nut
11	820390109	Setscrew
12	846271103	Hook cover plate
13	508614002	Idler (unit)
14	508073003	Idler set plate
15	625217100	Idler
16	000002806	Snap ring E-6
17	000115607	Setscrew TP 4x8
18	805603008	Feed regulator (unit)
19	508095001	Feed regulator shaft supporter
20	508067004	Feed regulator
21	805006005	Feed regulator shaft
22	000021801	Spring pin 2.5x12
23	000001609	Snap ring E-5
24	805007006	Feed regulator arm
25	000115906	Setscrew TP 3x12
26	000081005	Setscrew 4x8
27	805604009	Feed motor (unit)
28	000103509	Setscrew 4x10
29	805610008	DC motor (unit)
30	808502119	DC motor
31	000115504	Setscrew TP 5x10
32	805612000	Switching regulator (unit)
33	805606001	Printed circuit board P set plate (unit)
34	808504029	Printed circuit board P (unit)
35	805002001	Printed circuit board P set plate
36	000120203	Setscrew 3x8 (B)
37	805005004	Cord guide 1
38	000078320	Setscrew 3x6
39	805029004	Cord guide 2
40	805602007	Zigzag width motor (unit)
41	639098003	Zigzag width rod back plate
42	000002105	Snap ring E-3
43	627569106	Bobbin holder
44	102261000	Bobbin

PARTS LIST

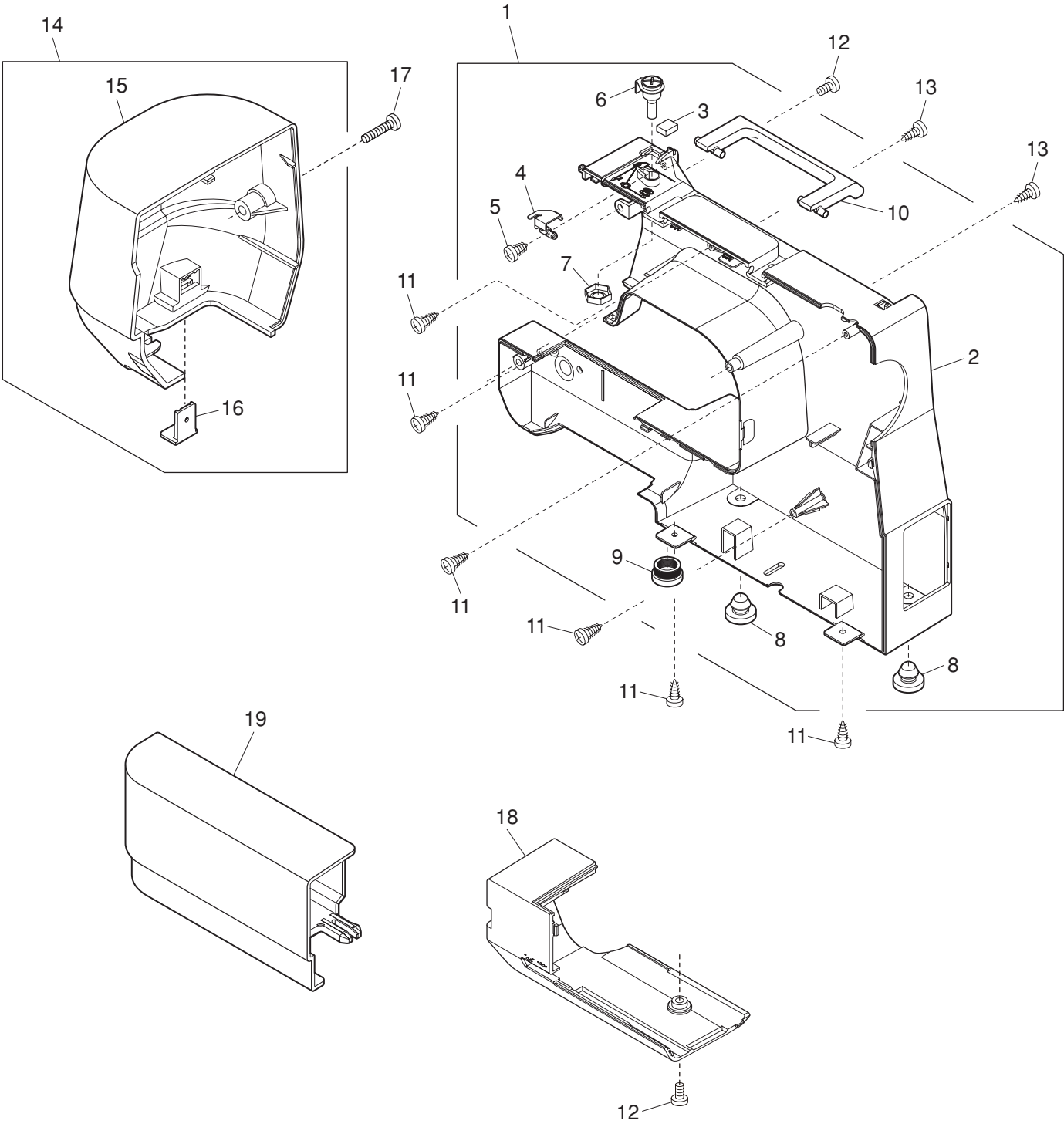

PARTS LIST

KEY NO.	PARTS NO.	DESCRIPTION
1	805607105	Rear cover (unit)
2	805016A02	Rear cover
3	660077002	Felt
4	660618001	Thread guide plate (unit)
5	000107307	Setscrew 3x8 (B)
6	730501011	Thread guide (unit)
7	000160102	Adjustable lock nut 4
8	525121000	Rubber base
9	525122001	Rubber base
10	508028003	Carrying handle
11	000161310	Setscrew 3x12 (B)
12	000081005	Setscrew 4x8
13	000108308	Setscrew 4x20
14	805609004	Face cover (unit)
15	805024009	Face cover
16	840602006	Thread cutter (unit)
17	000104108	Setscrew 4x20
18	805028003	Bed cover
19	805023008	Extension table (unit)

PARTS LIST

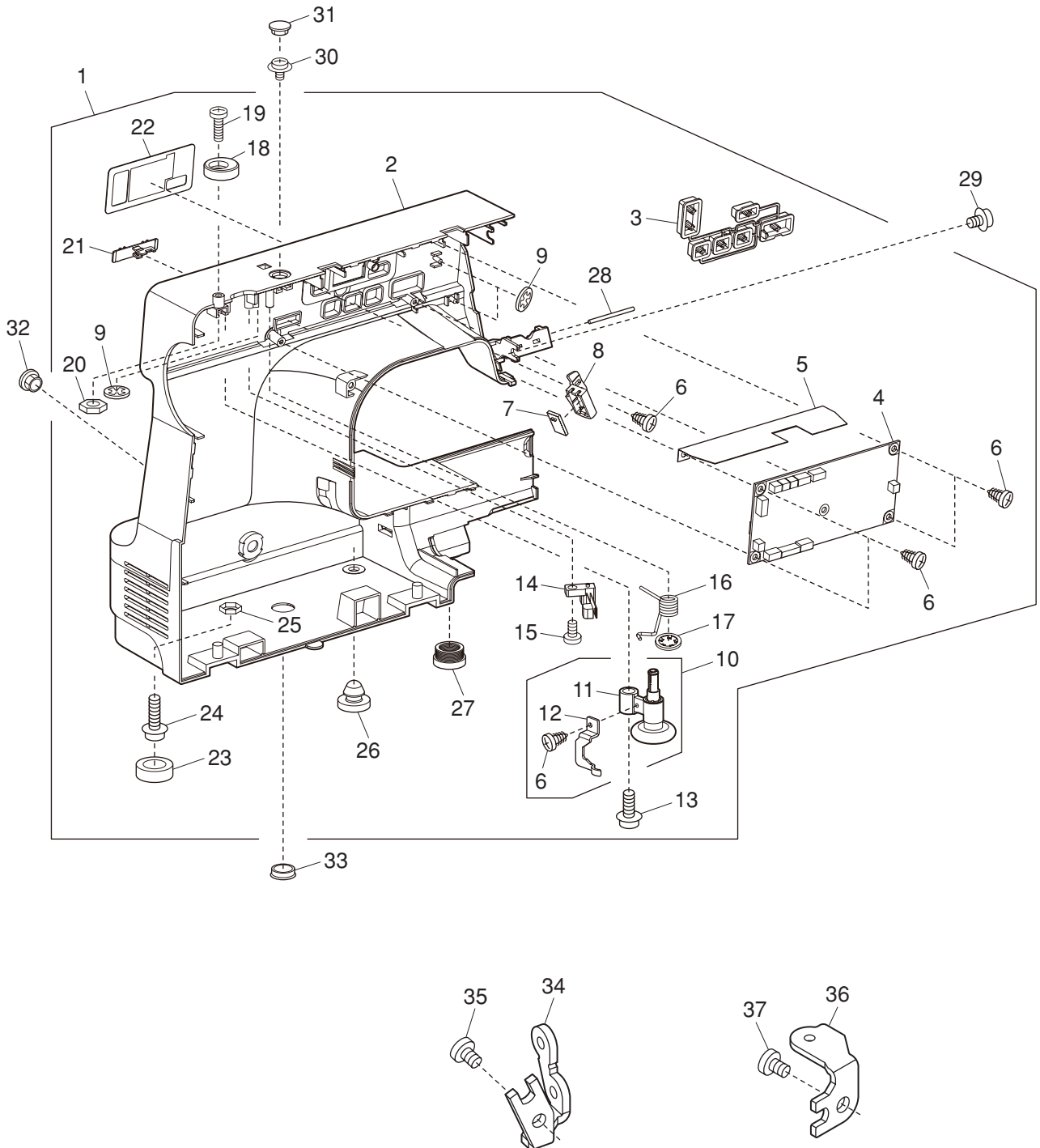

PARTS LIST

KEY NO.	PARTS NO.	DESCRIPTION
1	805608106	Front cover (unit)
2	805017A02	Front cover
3	805019A02	Button
4	805501201	Printed circuit board A (unit)
5	805021006	Flame retardant insulating paper
6	000120203	Setscrew 3x8 (B)
7	808506205	Printed circuit board L (unit)
8	808057000	Lamp holder
9	000014306	Snap ring CS-3
10	508620001	Bobbin winder (unit)
11	508507001	Bobbin winder arm (unit)
12	508111004	Clutch lever
13	000109103	Setscrew 4x12
14	856501106	Leaf switch (unit)
15	000120306	Setscrew 2.6x8 (B)
16	508030008	Spring
17	000013903	Snap ring CS-5
18	735016307	Bobbin winder stopper
19	000101817	Setscrew 4x16
20	000061205	Nut 4-3-7
21	805020005	Slide volume
22	805018A02	Ornamental panel
23	639005003	Rubber foot
24	000201405	Setscrew TP 4x16
25	000160102	Adjustable lock nut 4
26	525121000	Rubber base
27	525122001	Rubber base
28	806029007	Thread guide
29	000115205	Setscrew TP 4x6
30	000114709	Setscrew TP 3x6
31	653006101	Cap
32	805022007	SS adjusting cap
33	797141201	Cap
34	508093009	Front cover set plate
35	000101404	Setscrew 4x6
36	639080002	Front cover set plate
37	000081005	Setscrew 4x8

PARTS LIST

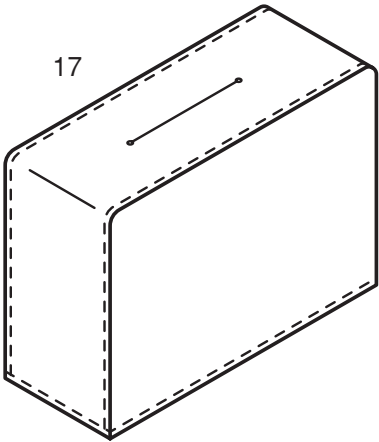
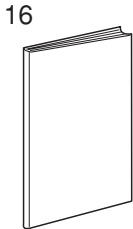
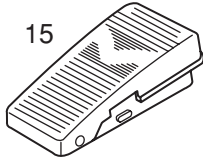
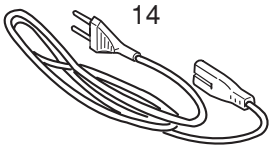
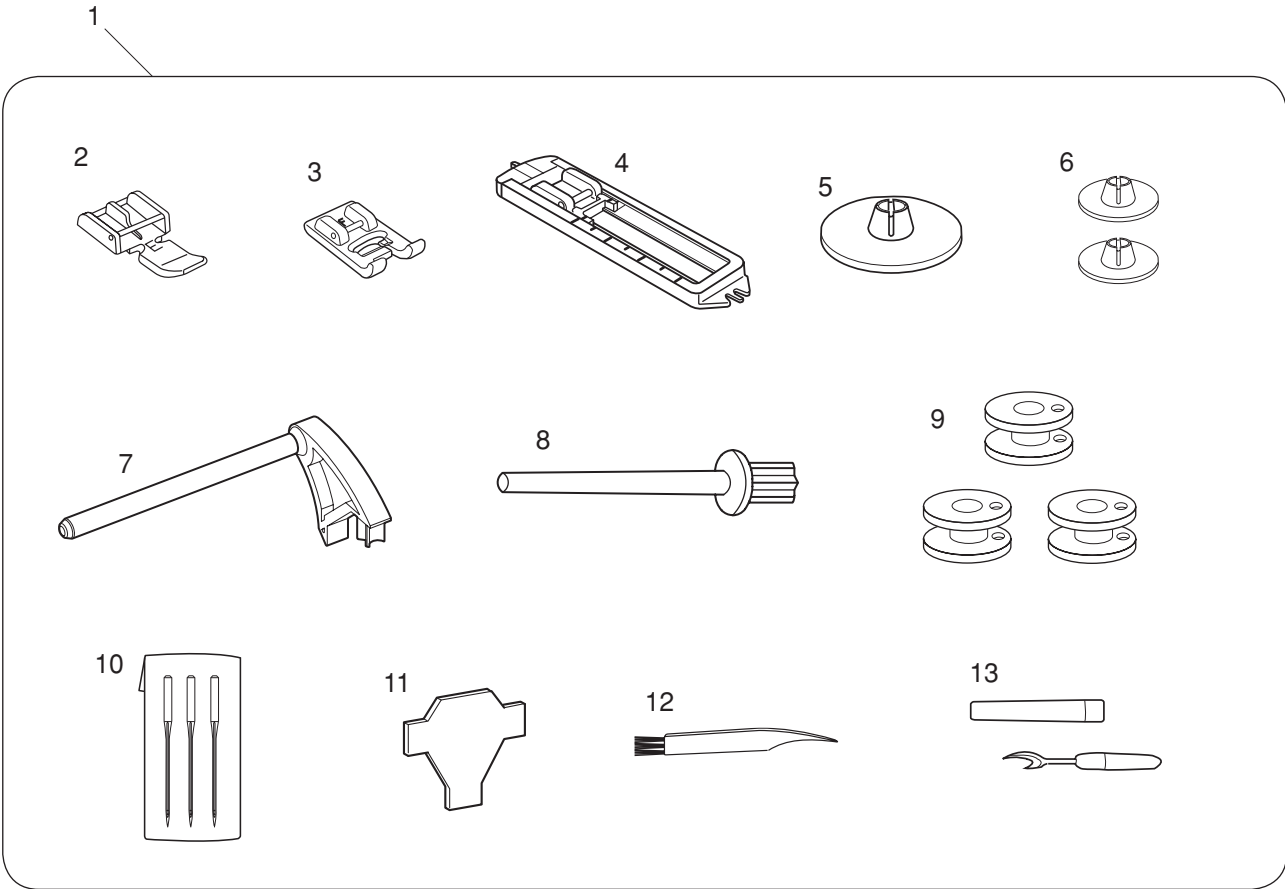

PARTS LIST

KEY NO.	PARTS NO.	DESCRIPTION
1	805870019	Standard accessories
2	808852003	Zipper foot E
3	822804118	Satin stitch foot F
4	508803000	Sliding buttonhole foot
5	822020503	Spool holder (large)
6	822019509	Spool holder (small)
7	660005010	Spool pin
8	625031500	Extra spool pin
9	102261000	Bobbin
10	639804000	Assorted needle set
11	653802002	Screwdriver
12	802424004	Lint brush
13	647808009	Seam ripper (Buttonhole opener)
14	830335004	Power cable
15	808550008	Foot control
16	805800007	Instruction book (English)
17	661802007	Cover